

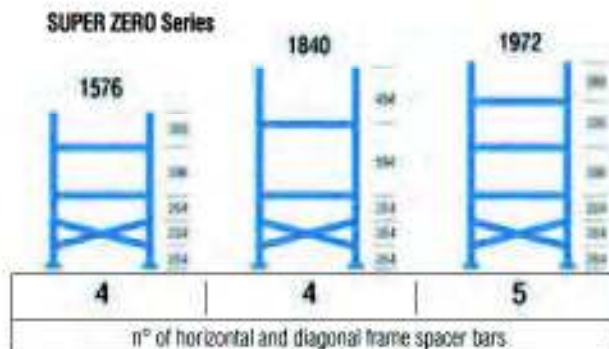
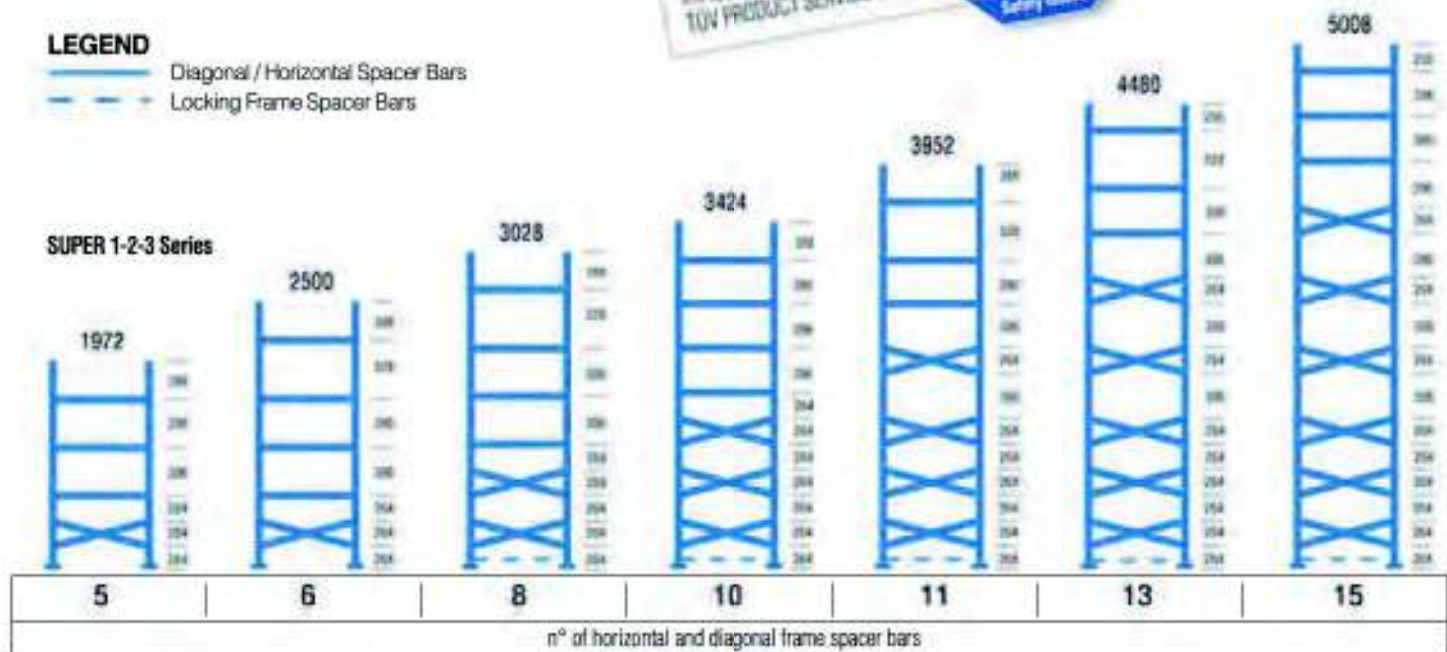

DIAGRAM FOR ASSEMBLING BRACING FOR FRAMES

320 - 400 - 500 - 600 - 700 - 800 in depth

LEGEND

-  Diagonal / Horizontal Spacer Bars
-  Locking Frame Spacer Bars



SUPER-ZERO uprights and frames are allowed with the use of SUPER-ZERO beams and shelves, only. Bay lengths 900/1050/1200 mm only, with a max. load capacity of 200 daN per shelf, for uniformly distributed loads.

TWO TIER STRUCTURES PLATFORMS

In case of two tier structures with suspended walkways the frames are to be assembled as shown in case "A" at left (i.e. the standard frame assembly diagram). In case of platforms with continuous floor decking, the frames have to be assembled with pairs of diagonal spacer bars only, at centre distances of 264 mm, up to the level of the platform (see case "B" at left).

In both cases the frames must be securely bolted to the floor slab using the heavy duty base plates (art. n° 67006.95) and the locking frame spacer bars.

Staircases made from standard components and integrated into the two-tier-structure have to be reinforced in an appropriate way, using the reinforced SUPER 3-upright (art. n° 99230.95) either side of the staircase. METALSISTEM strongly recommends to comply with all safety standards mentioned in this brochure.

The maximum load bearing capacity of walkways/decking within two-tier structures or platforms is 300 kg/m² and the maximum width of the walkways is 1200 mm. The maximum shelf bay length is 1500 mm.

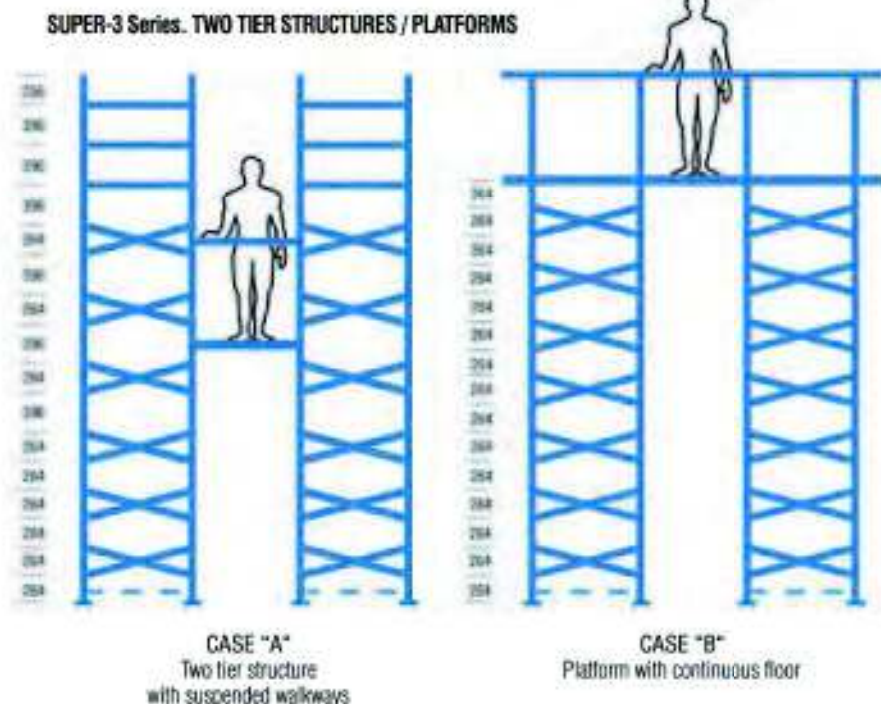







THE COMPANY TODAY

METALSISTEM products are now in use in a great many installations throughout the world, and after more than 40 years production, we value greatly the high level of trust that is placed in us by our customers and feel that it is proof of the quality of our products.

The shelving components are produced on fully automated production lines.

The folding and cold processing techniques developed by METALSISTEM are designed to obtain light and extremely strong components.

Lightness, strength and modular form coupled with the ease of integrating and expanding already existing structures are but a few of the successful features of the METALSISTEM Industrial Storage Systems. Ideal storage solutions for a whole host of products supplied worldwide are created here thanks to a total commitment to research and development.

All METALSISTEM components are subjected to regular and rigorous technical tests. These cover both uniformly distributed and concentrated loadings.





THE PRODUCT

The fully adjustable SUPER 1/2/3 systems have been designed to meet the needs of light to medium duty storage. They are also highly suitable for the construction of two tier structures (with the SUPER 3 system). The design of the various components is the result of rigorous technical testing and the highly specialised knowledge developed over years of experience in the field of metal processing.

This experience has enabled METAL-SISTEM to offer innovative products of the highest quality, highly competitively priced, and to produce a highly technical solution to the most important



shelving problems, such as rapid assembly, stability, low cost and load bearing capacity.

The design allows for high load bearing from light gauge materials. The use of high quality zinc coated steel ensures a high level of durability.

The structural components of the SUPER 1/2/3 systems are made from high tensile steel, certified according to EN 10204 3.1.





The safety and the quality of the product has always been a primary aim of METALSISTEM and is recognised by TÜV PRODUCT SERVICE in Munich, one of the most rigorous E.C. commissions in the field of quality and safety certification. The product meets the requirements of the Equipment Safety Law.

Thanks to its attractive high-tech design, SUPER 1-2-3 shelving is trendy and pleasing to the eye. It can provide unique and cost effective solutions for shopfitting and applications in domestic environments as well. See examples at left.



ASSEMBLY INSTRUCTIONS

Base plates

Fit the steel base plate onto the upright, using pliers to guide the two tongues on the plate into the ribs on the upright. Then tap the base plate into the ribs with a hammer (see sketch below).

Plastic base plates (Ref. 1) should be used for the SUPER-0 and SUPER-1 series only. They may be used as well for applications in domestic environments, with modest load bearing capacities. Double plastic base plates are available for back-to-back bays. Both items (single and double base plates) are also used as top caps for uprights (Ref. 20/29).

Heavy duty base plates (Ref. 1b) must be used in the following cases:

- when building platforms or two-tier structures with suspended walkways;
- when building staircases, under the uprights of the staircase;
- if the height of the shelving is over 3 metres or exceeds over 5 times the depth of the shelving.

Heavy duty base plates are always to be assembled in conjunction with locking frame spacer bars.

In all other cases customers may use the standard steel base plate (Ref. 1). Shims in 1 and 2 mm gauge are available for steel base plates.

Spacer bars

To fit spacer bars, refer to the diagram on pages 4/5 to determine the exact position and quantity.

Insert the horizontal and diagonal spacer bars into the grooves in the corner of the upright, locating the wide part of the slot over the ribs on the upright and keeping the spacer bars tight to the upright, in order to keep it square; then tap down into the narrow part of the slot alternating from side to side.

To achieve correct assembly, the spacer bar anti-release tongues should be closed (Ref. 2).

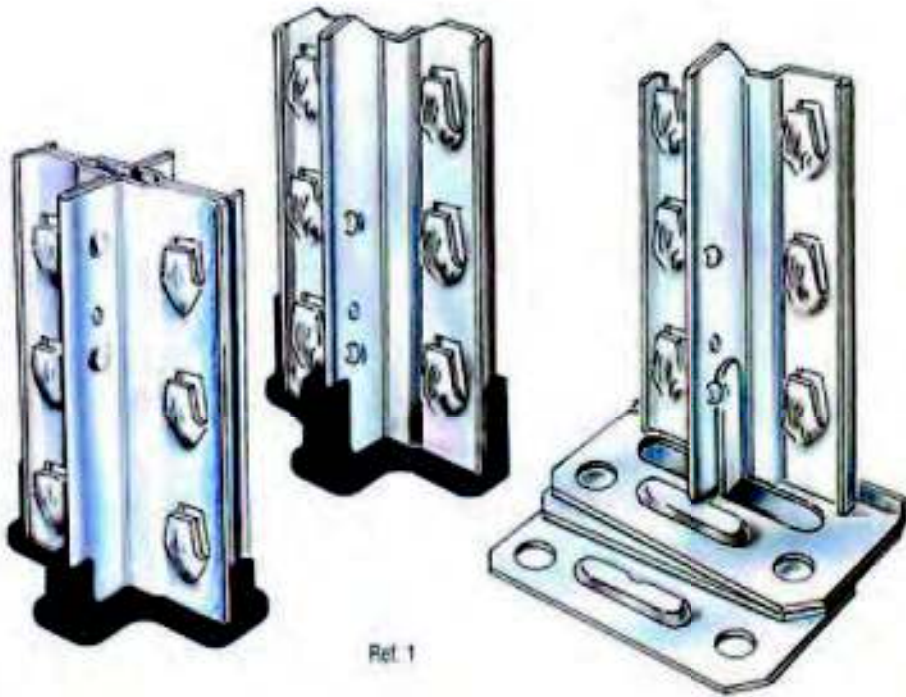

Ref. 1



Ref. 1b



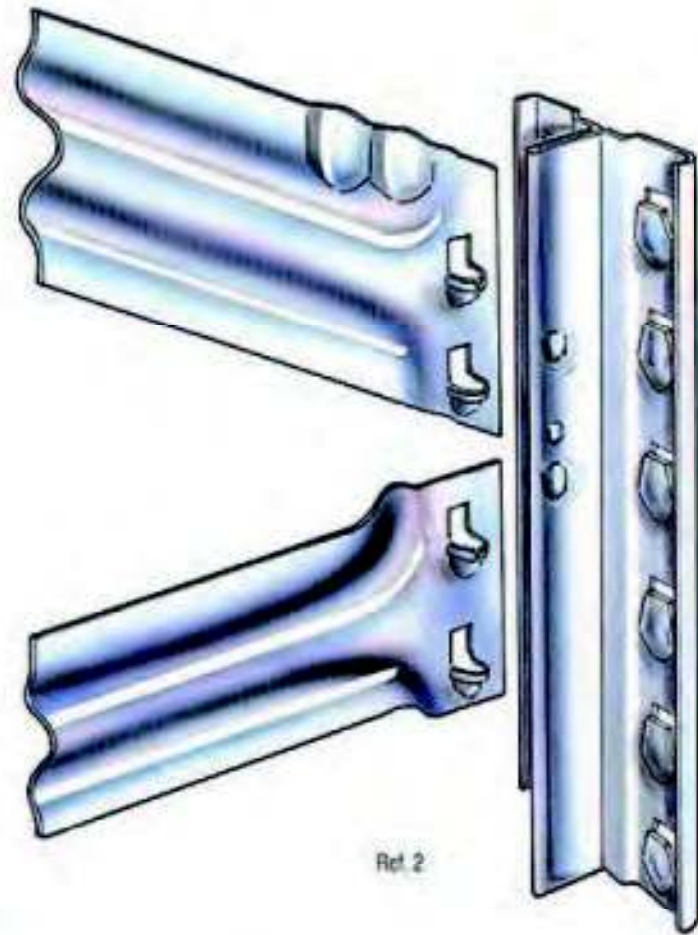

Ref. 2

Beams

Take the frames, assembled with bracing and base plates: keep them as perpendicularly as possible and fit the beam by tapping it down onto the tongues, close to the upright, with a plastic-faced hammer to avoid damage to the beam (Ref. 3).

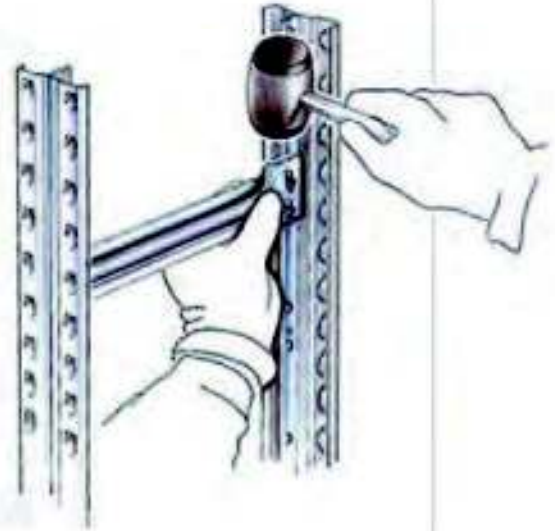

The beams, once assembled, should be secured with the respective beam locking pins (see page 21, Ref. 22).

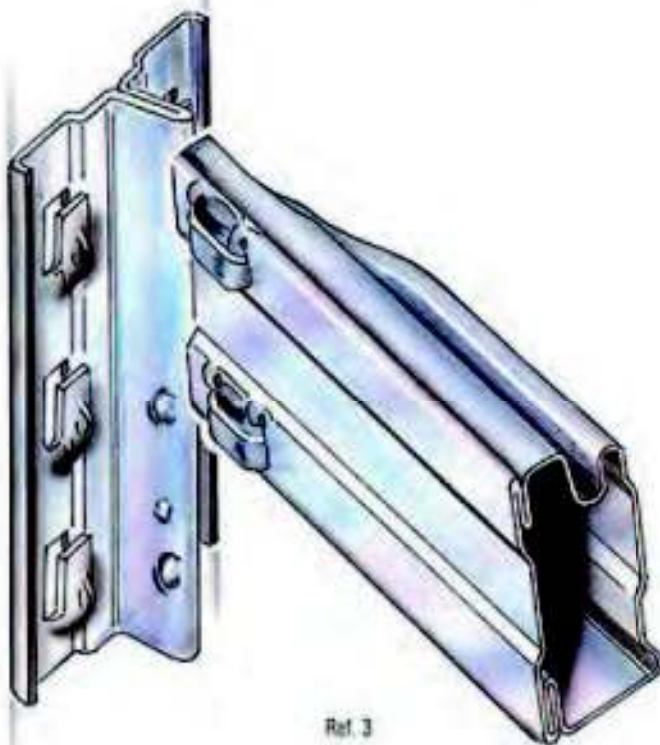

Ref. 3

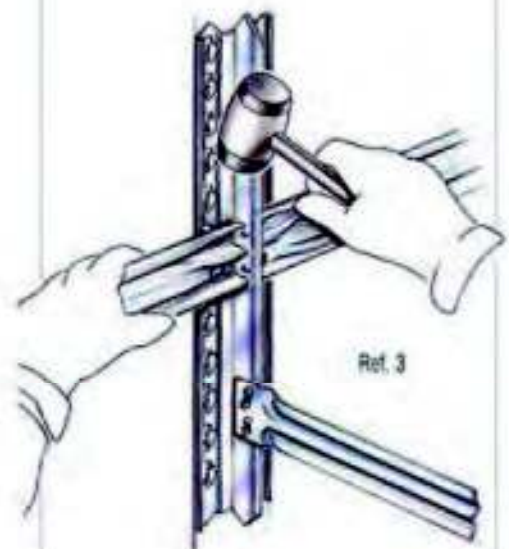

Ref. 3

For the storage of tyres or round materials which are placed directly onto the beams, plastic strips are available to avoid damage to the products stored; these strips are fitted into the recess of the beams (see page 21, Ref. 21).



Roller Shelves

Roller shelf units consist of one or more inclined runways equipped with specially designed roller tracks. Merchandise is loaded in the rear of each runway and moves toward the picking station. As an item is removed from the front, the item directly behind it slides forward in place of the previous and rolls to the front, thus allowing merchandise to remain better organized and easier to find/pick.

METALSISTEM's carton flow is an economic, modular and functional solution based on standard components alone, allowing flow track beds to be created up to depths of 4 metres. The flow track profiles are made from certified, galvanised, high tensile steel and are manufactured in lengths ranging from 359 to 4022 mm at a cut pitch of 33 mm. Yellow rollers made from polypropylene are inserted into the tracks at varying pitches of either 33, 49.5, 66, 82.5 or 99 mm, according to the application requirements. The track profiles are inserted into sceenstrips that are fastened with clamps/screws (art. 69829.95/00056.20) at centre distances of approx. 1000 mm.

The support for the roller shelves is provided by frames placed at fixed intervals set by oval tubes, (the same standard components used for walkway parapet elements) thus ensuring that the beams will be aligned at a constant inclination of approximately 8% from the rear to the front side of the system. However, the most suitable degree of inclination depends on the type of packaging and weight of the load unit and the overall length of the roller track. A "T"-section support bar placed at the picking side of the run provides both support for the flow tracks and an end stop for the cartons. For more information please refer to page 44 of this brochure.

Chipboard shelves

Chipboard shelves of thickness 12 or 18 mm can be fitted using the clips shown below (Ref. 8).

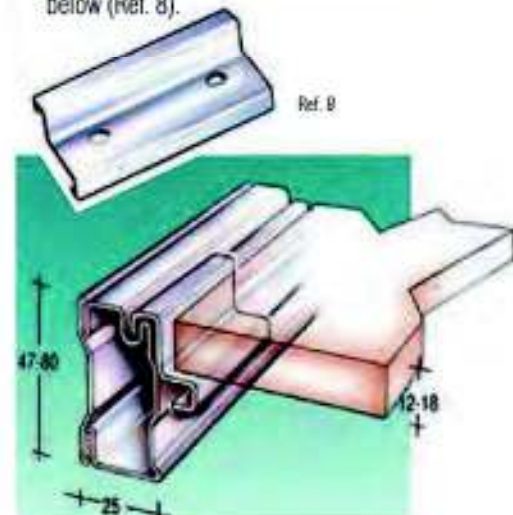

Shelves H12 and H25

Shelves of profile 12 mm, 450-600-900 mm wide, are produced in depths varying from 320 to 700 mm. Shelves of profile 25 mm and 300 mm wide are supplied in depths varying from 400 to 800 mm (Ref. 5-6).

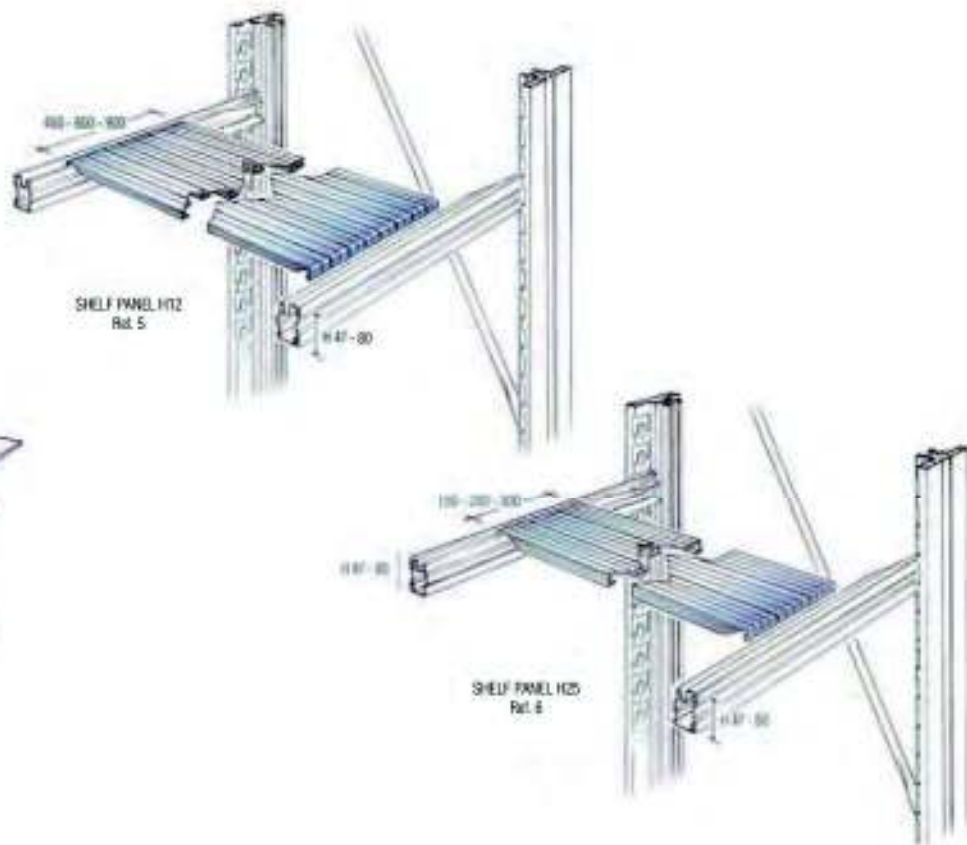
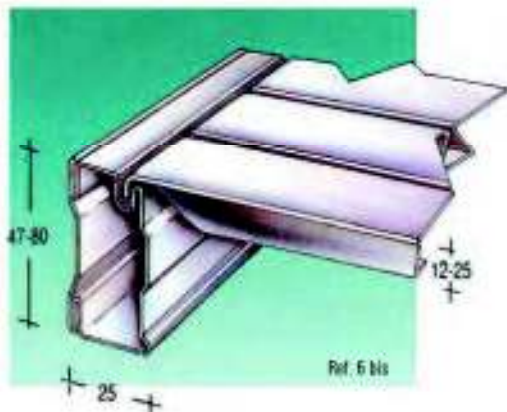

Perforated Plastic Shelf Panels

The standard range of perforated plastic shelf panels in 150-200-300 mm width is made from high quality polypropylene, suitable for use within the food sector, perforated at >50% of the shelf surface area. Available in four different colours: white, yellow, light blue and blue, for frame depths 320-400-500 mm (Ref. 60).

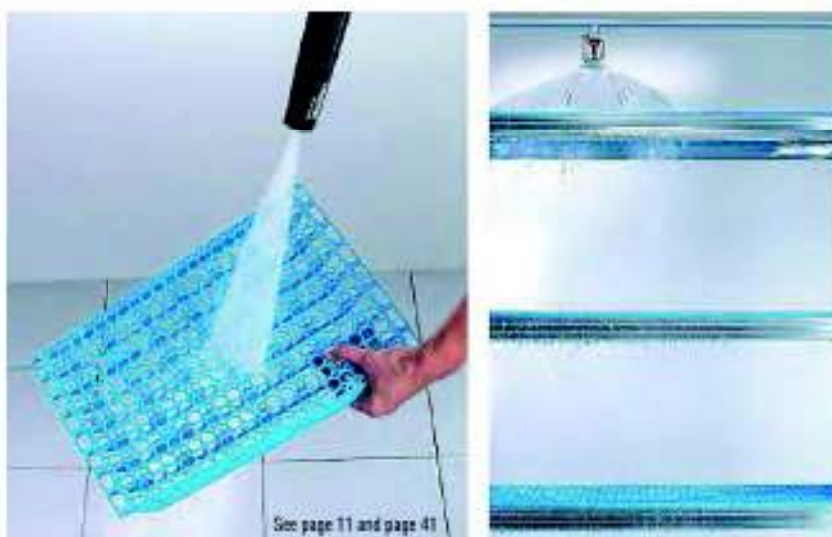

Specific FROST panels in light green colour are available for use within cooling rooms. ECO shelf panels in black colour, made from recycled polypropylene, feature utmost cost efficiency. ECO shelf panels are not compatible with the food sector.

For correct ordering and load bearing capacities, please refer to page 41 of this brochure.

Perforated Steel Shelf Panels

Perforated steel shelves of profile 25 mm in 300 mm width, perforated at 50%. For installations equipped with sprinkler systems. Hole diameter 6.5 mm. For correct ordering and load bearing capacities, please refer to page 43 of this brochure.

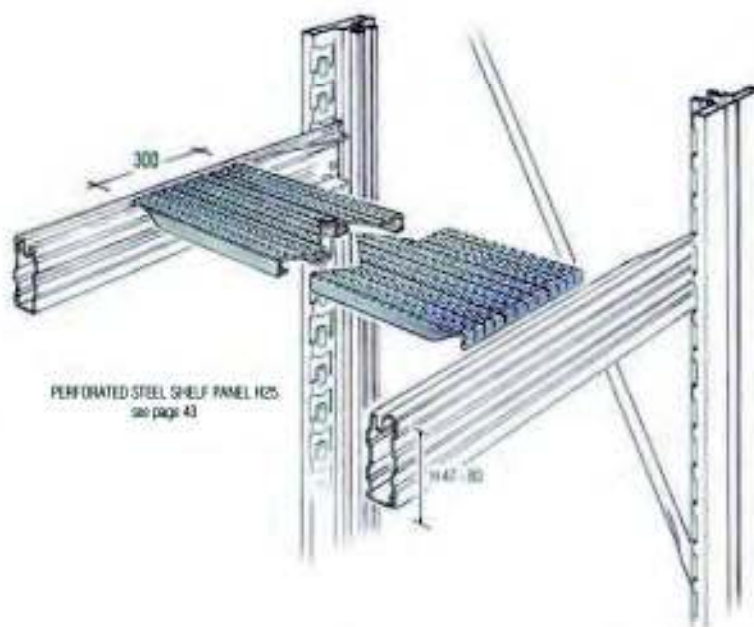

Modular containers

Insert the containers from left to right, and join them together by overlapping the beginning of the following container onto the end of the preceding one, pressing them into the recess of the beams.

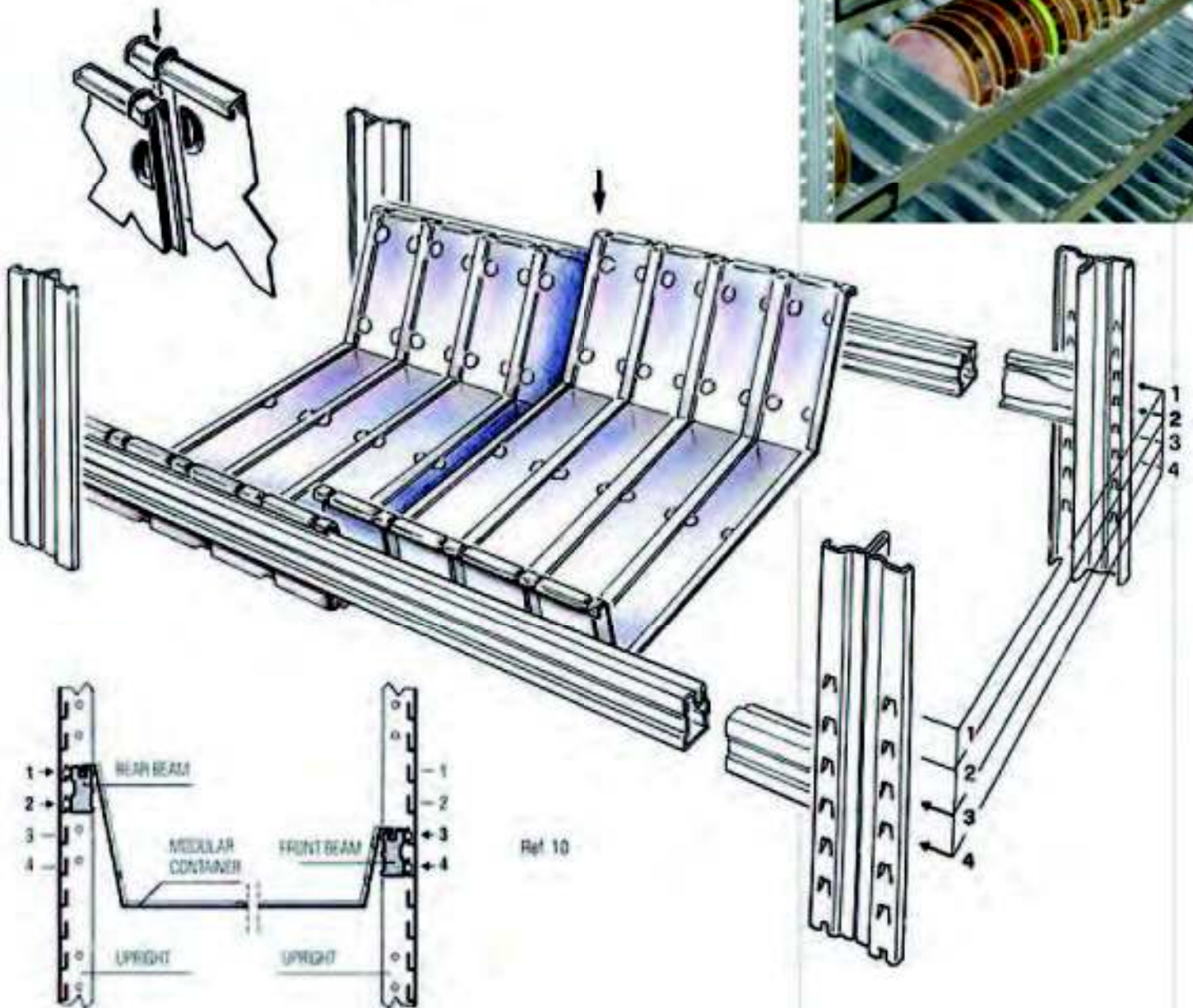
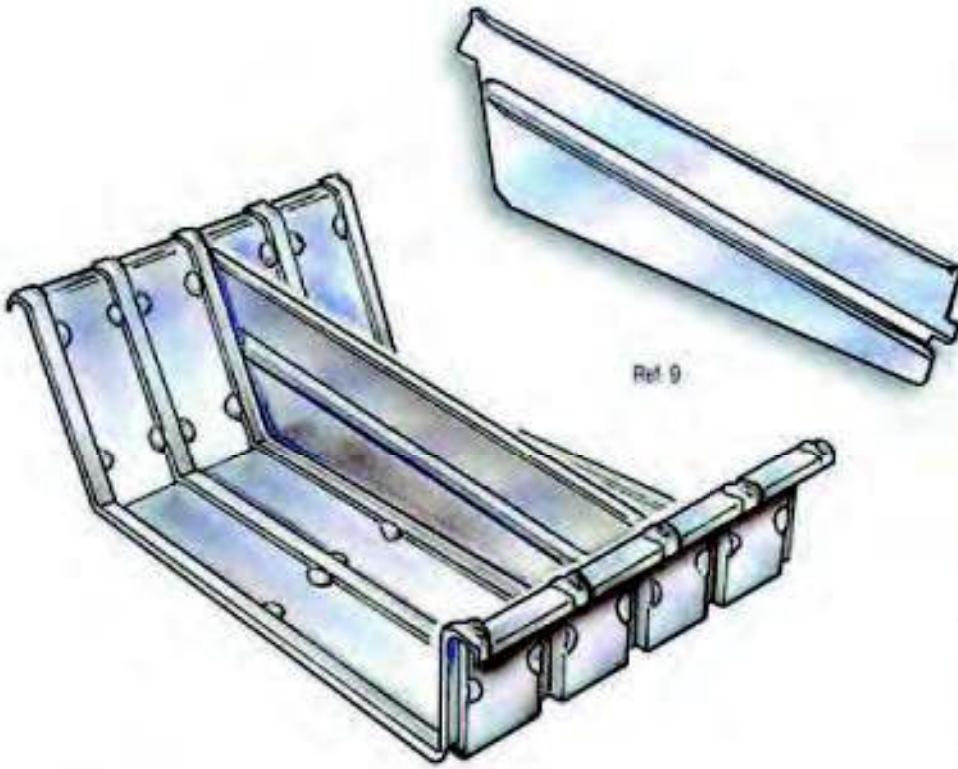

To assemble the containers correctly, the rear beam should be fitted two pitches higher than the front one (Ref. 10).
Fit the dividers into the special slotted seats, pushing down to locate (Ref. 9).



The capacity of the containers can be increased by fitting bin front and rear panels 200 or 300 mm high.

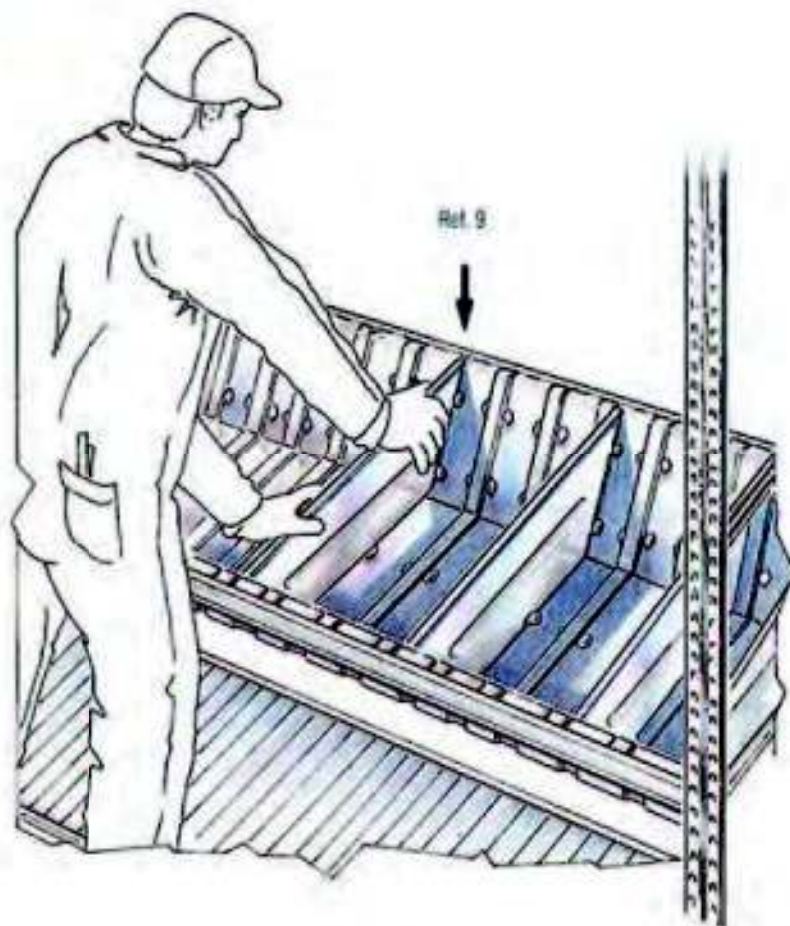
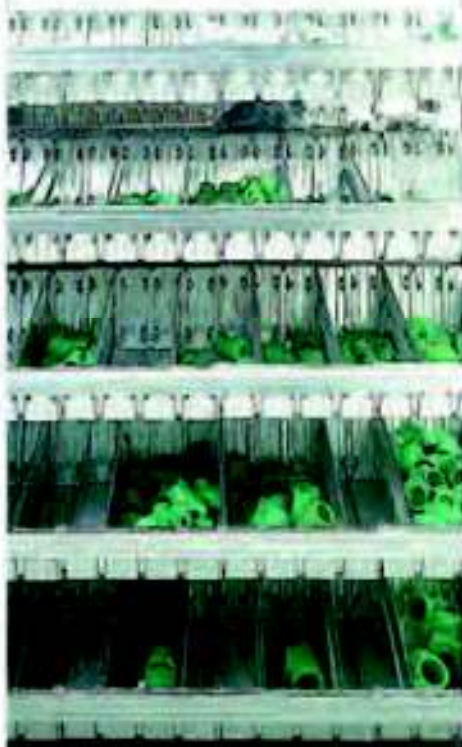

DIVIDERS

A large range of dividers is available.

Vertical sliding dividers

These have been designed to separate loose items (Ref. 11). The concept of these dividers is based on the following components: a couple of clips (version at right/at left), and vertical dividers, available for all frame depths and in two different heights (H=100mm / H=200 mm), as well as in the profiled version (H=200/100 mm).

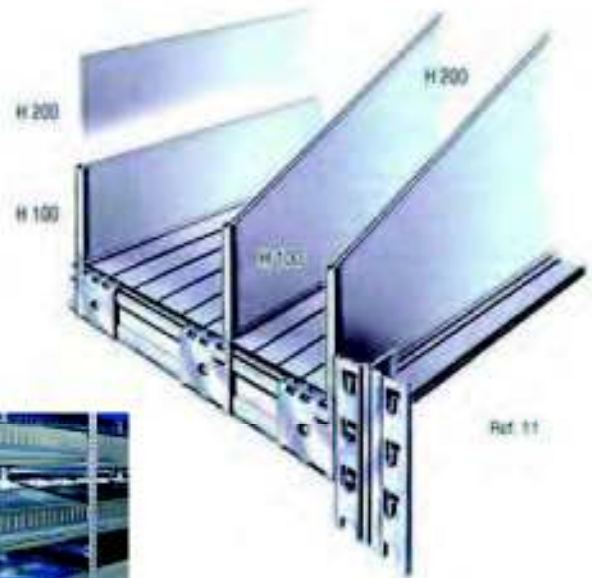

Shelf trays

These comprise a bin front and rear panel 100 mm high placed on a normal shelf with adjustable dividers from 320 to 600 mm in depth (Ref. 13).



Chest of drawers

The modular drawers are fully integrated with the SUPER 1-2-3 series and are located directly on the frames.

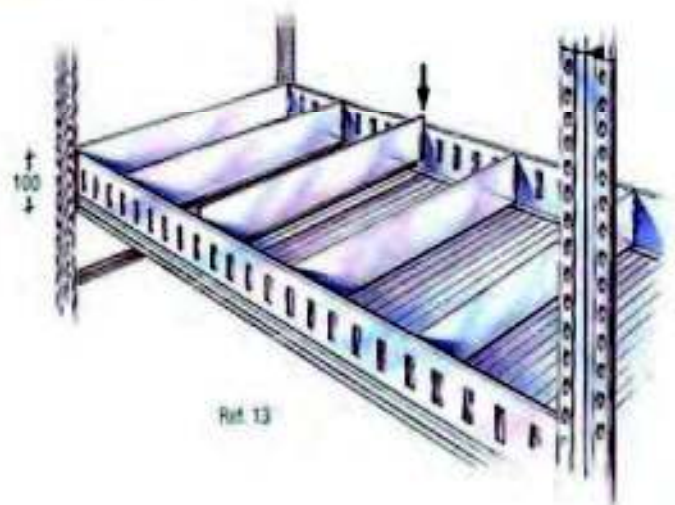

A cost effective solution for the storage of small items.

Bin front panels 100 mm high and rear panels 200 mm high are fitted with profiled dividers (Ref. 14/15).

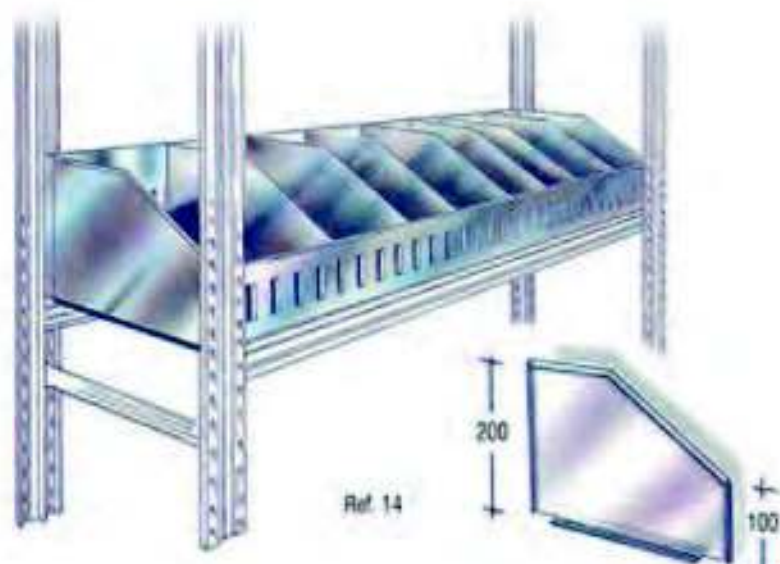
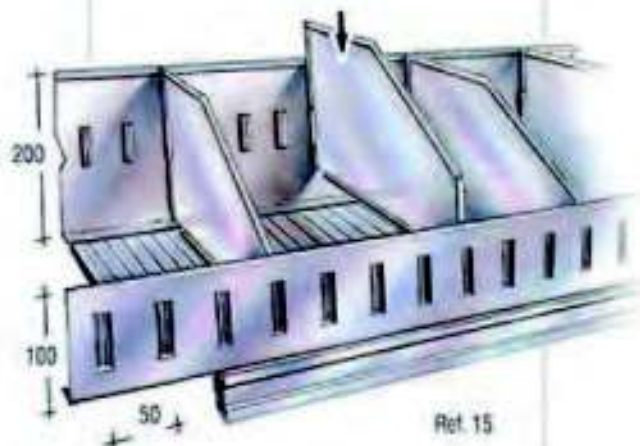



Plastic Bins

Open fronted plastic bins are also available for the storage of loose items. More information on page 51.

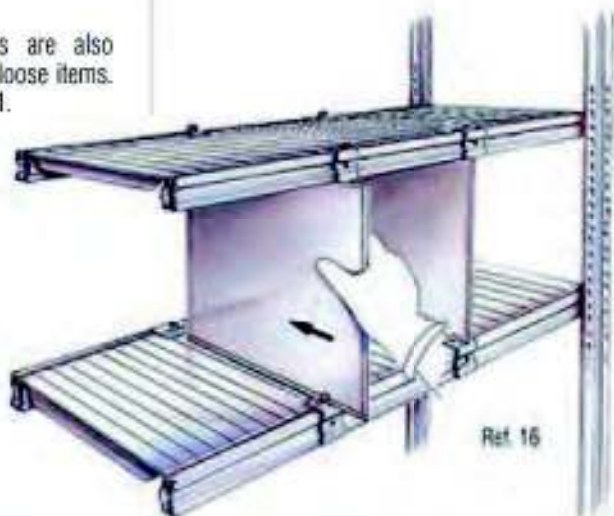

Fixed height dividers

Available in three different heights: 244-344-444 mm
They can be inserted in any position on the shelf by means of spring clips located on the beams H47 (Ref. 16).





Telescopic Tube Dividers

Used for the separation of cylindrical components or materials difficult to store (windscreens and panels, etc.). They comprise 2 tubes of 18 mm diameter sliding one inside the other. They are fixed to the upper shelf by means of a clamp/screw connection (8mm). A minimum of two tubes should be used for each division (Ref. 17).



Ref. 17

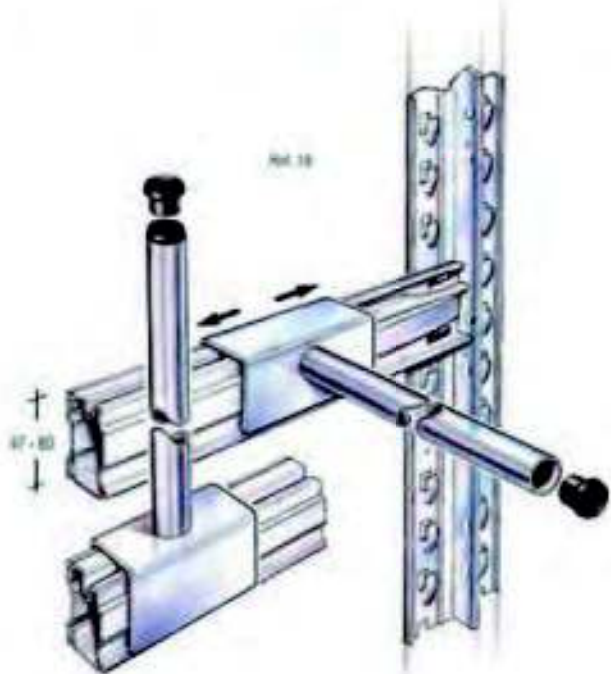

Ref. 18



Dividers for exhaust pipes

Spigots designed for the separation of tubes, exhausts and conduits, etc. They are used both vertically and horizontally and are fitted on to the beams anywhere in the length. Not suited for hanging loads (Ref. 18).

Label Holder

It can be located in any position on both H47 and H80 beams. Dimensions 100x40 mm (Ref. 23).

ACCESSORIES

PVC top caps

PVC top caps are to be fitted onto the top of the upright, in all applications (Ref. 20).

Oval shaped tubes and beams

The oval shaped beams and tubes are compatible with most types of hanger and provide a cost effective solution to garment storage and for hanging loads (Ref. 19/20). The garment hanging shelving can be designed on a single or double entry basis and equipped with shelves. The oval tubes fitted onto the spacer bars alone will not stabilise the structure in the horizontal plane and have to be combined with beams above and below.

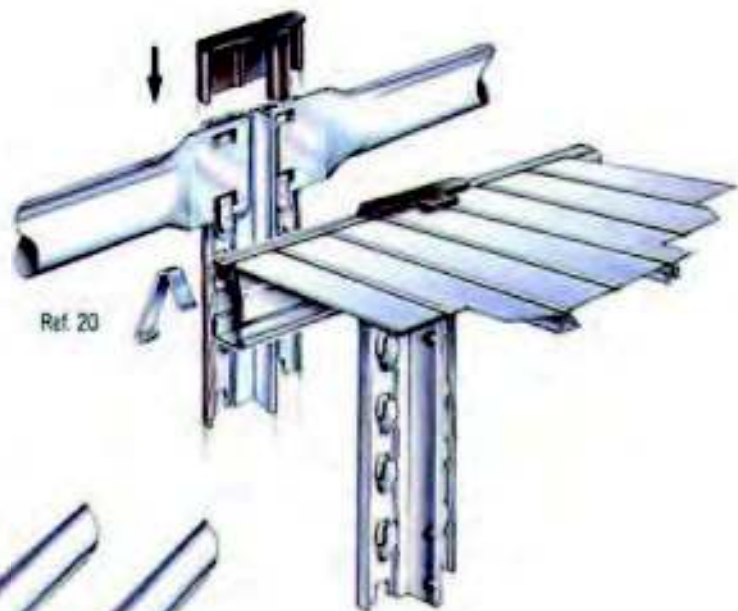

Ref. 20

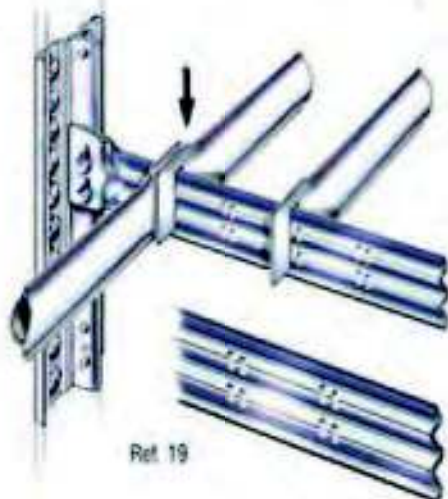

Ref. 19

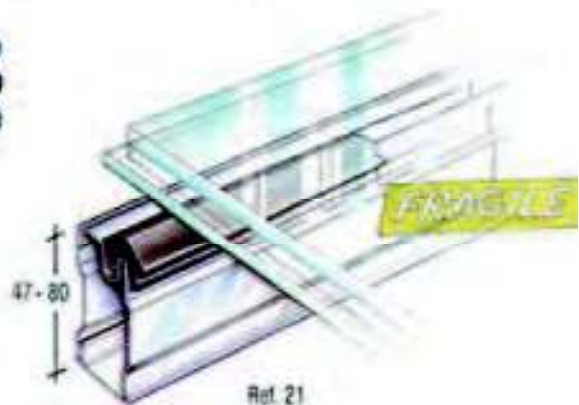

Ref. 21

Tyre Storage

The oval shaped beams can also be used for the storage of tyres (see page 10).

In this case, please refer to the technical handbook to identify correct use and appropriate load capacities.

In the case that the tyres will be stored on H47 mm beams, it is obligatory to use the SUPER-3 version only and exclusively, both for the beams and the frames. Maximum allowed bay length: 1200 mm. Maximum allowed frame depth: 400 mm, to ensure safe storage and to prevent torsional deflection of the beams.

Plastic strip for glass shelves

It can be fitted on the beams in order to protect glass shelves or delicate materials (Ref. 21).

Security pins

In order to prevent accidental lifting of the beams and shelves, the security pins should be used in all applications (Ref. 22).

Assembly instructions as per the sketch at right.



Ref. 22



Ref. 23

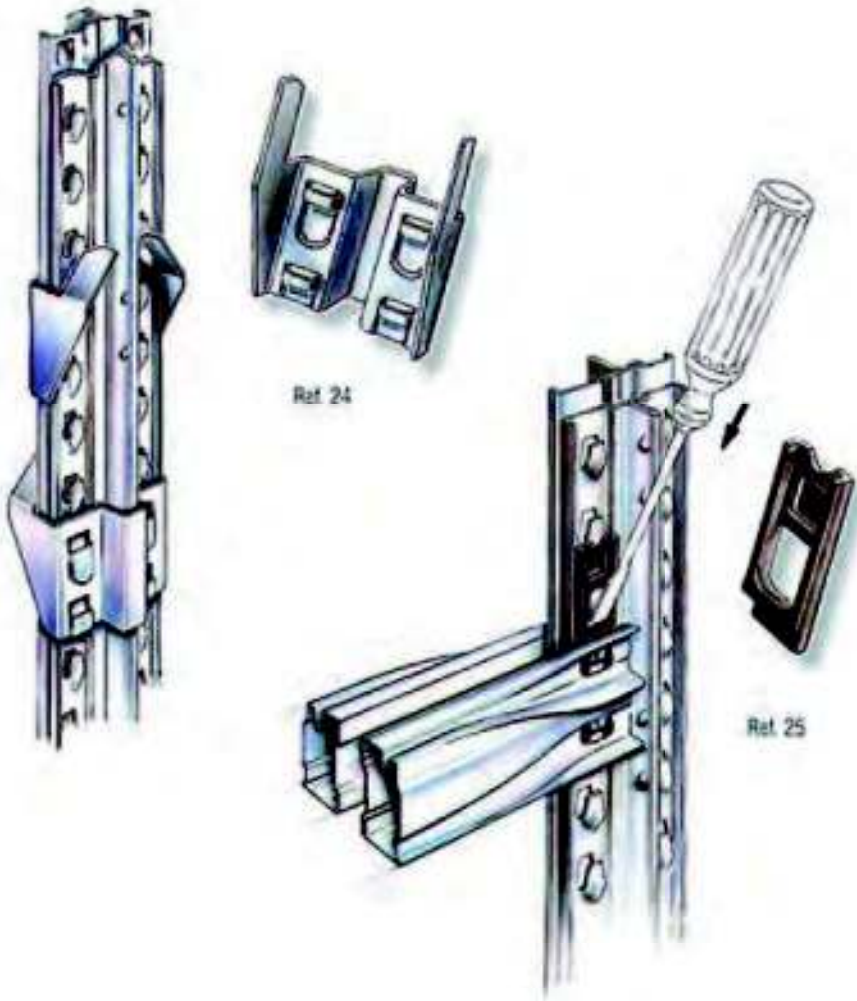

Frame back-to-back clips

They are used to fix the frames together when building back-to-back bays to improve stability. They are located at mid height (Ref. 24).

Security pins for beams in back-to-back bays

They are used to prevent accidental lifting of the beams when building back-to-back bays (Ref. 25).



CLADDING END PANELS H25

End panels are manufactured in two standard sizes (200/300 mm wide x 25 mm) and in standard heights of 1485-1940-2480 mm (Ref. 26). End and middle joints are also available to build multiple cladding heights and/or to finish off the panels at their upper end (Ref. 31).

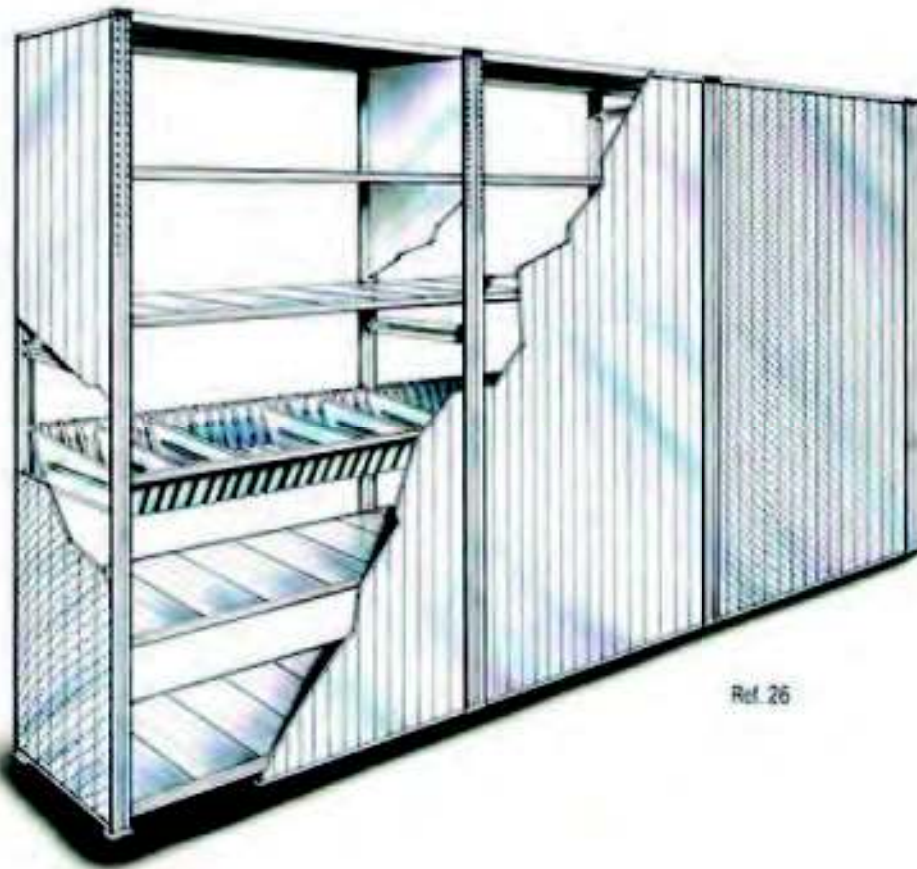

In case of the panels being lower than the respective frame, "H"-section profiles may be used at the bottom of the panels, to achieve equal height (Ref. 31).



Punched hole panels H25 are also available; according to European Standards (i.e. hole diameter of 5 mm, at 25 mm centre distance). Special clips are used to fasten the cladding panels. For end panels it is the clip art. code n° 68107.95 (Ref. 28), for back panels H29 mm it is the clip art. code n° 68108.95 and for back panels H12 mm the clip 67010.95 (Ref. 27).

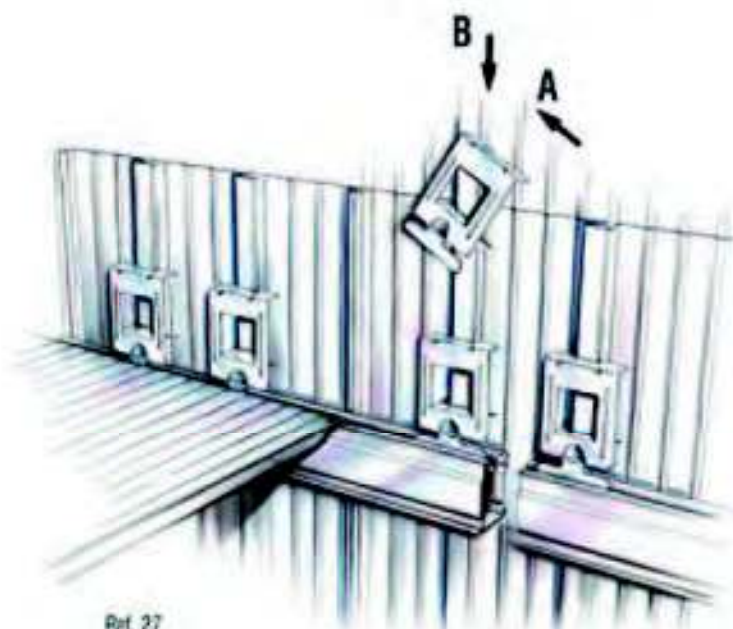

Ref. 27

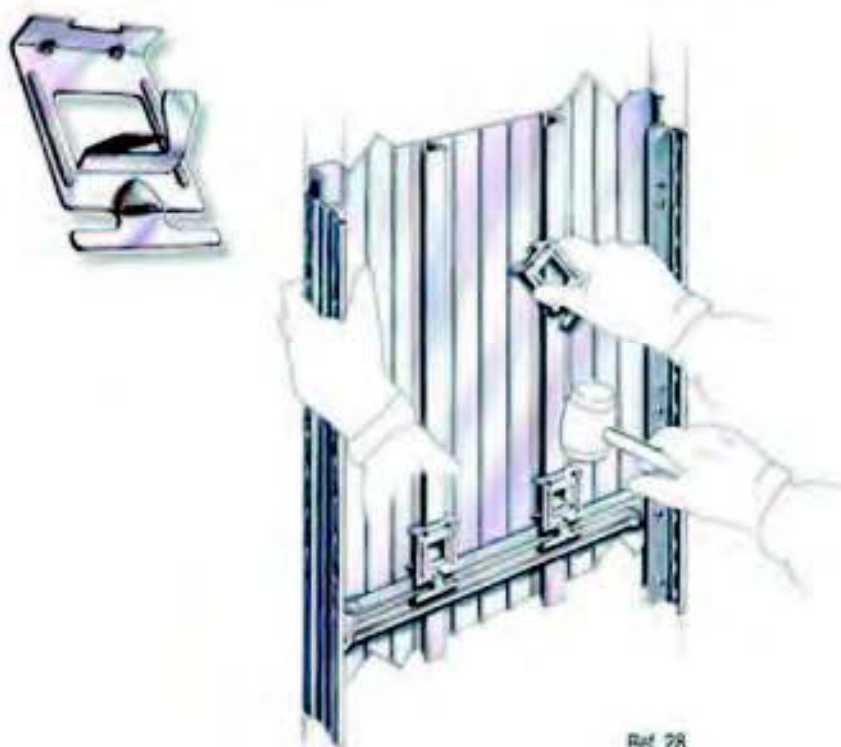

Ref. 28

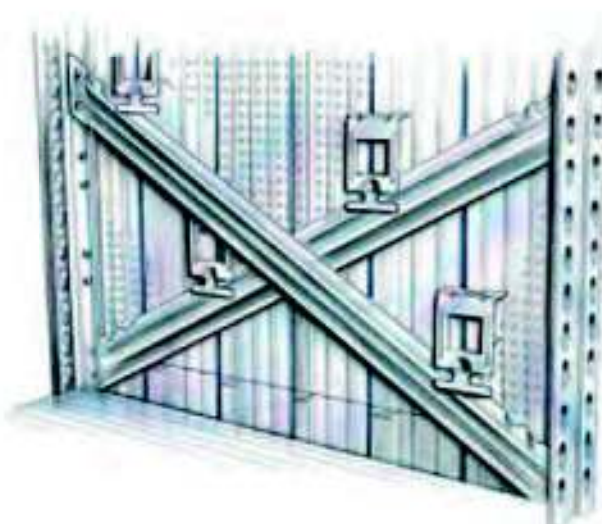

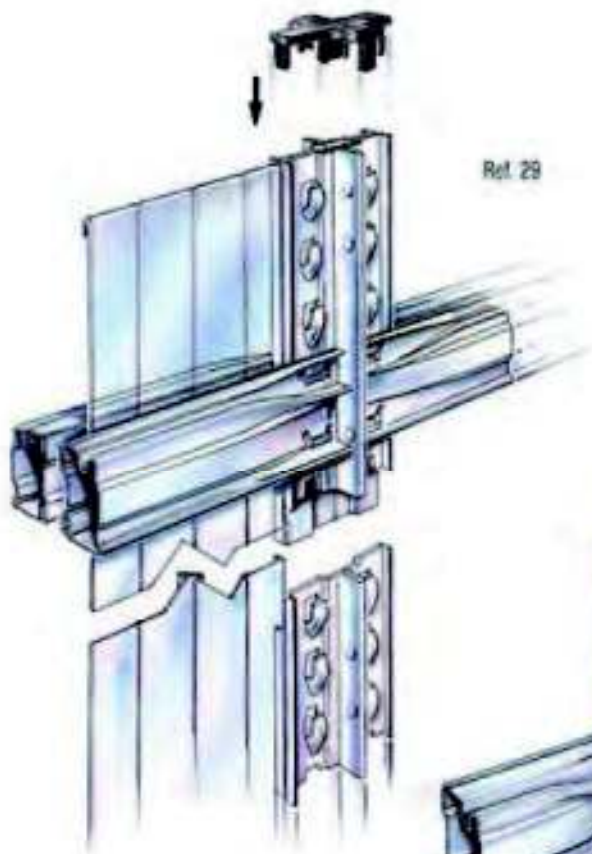

Ref. 29

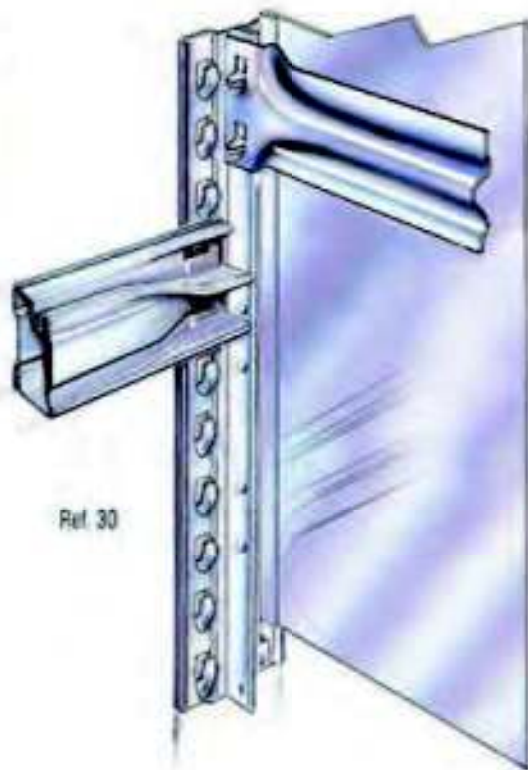

Ref. 30



Ref. 31



Side cladding

This type of cladding may be used to enclose individual bays within shelving runs. Available for frame depths up to 600 mm. Side cladding panels are fitted between the diagonal spacer bars of the frames. When ordering side frame claddings, the respective frames are to be built with diagonal spacer bars only, i.e. the horizontal spacer bars have to be replaced with diagonals (Ref. 30).



MODULAR SLIDING GATE

The modular METALSISTEM sliding gates are supplied preassembled, in kit form. Two different models are available: with guide rail assembled on the ground or with external, suspended guide rails, made from a USP-upright profile supplied in standard lengths of 4500 mm which has to be cut to size on site according to individual needs. For available dimensions and ordering, please refer to page 48 of this brochure.



CLADDING BACK PANELS H12 mm for back-to-back bays

Back panels H12 are manufactured in 450-600-900 mm standard width and in standard heights of 1485-1940-2480-2980 mm (Ref. 29). When using H12 mm panels within back-to-back bays, the single modules are superposed at the center of the bay (see sketch below). The cladding modules are kept in position by the beams of the back-to-back bays. For multiple cladding heights, a couple of beams has to be located at junction points (Ref. 31).

The sketches shown below and beside explain the design and assembly of the various cladding components.

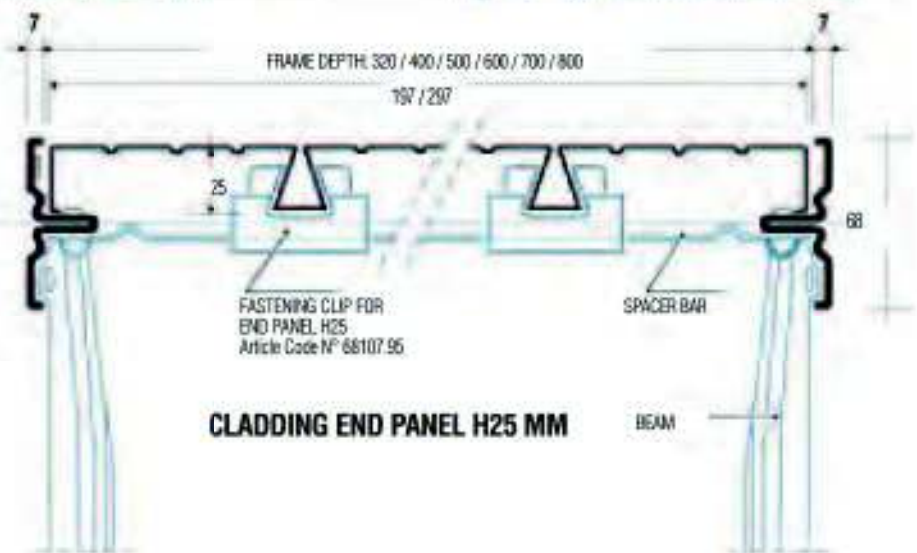

BACK CLADDING H12 MM

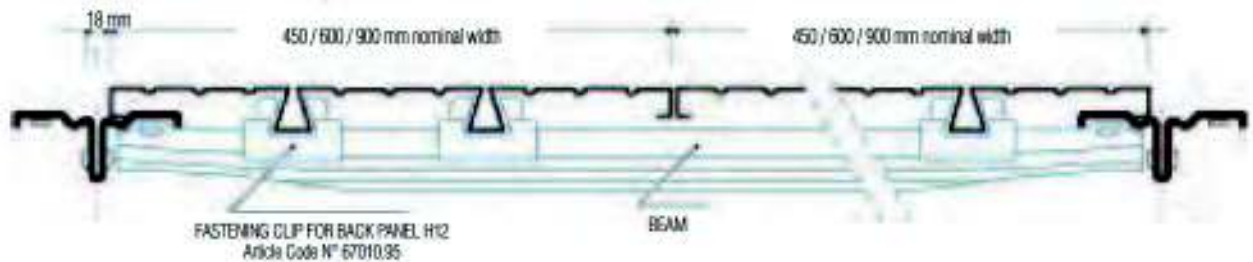

CLADDING PANELS H-12-MM - FOR BACK TO BACK BAYS

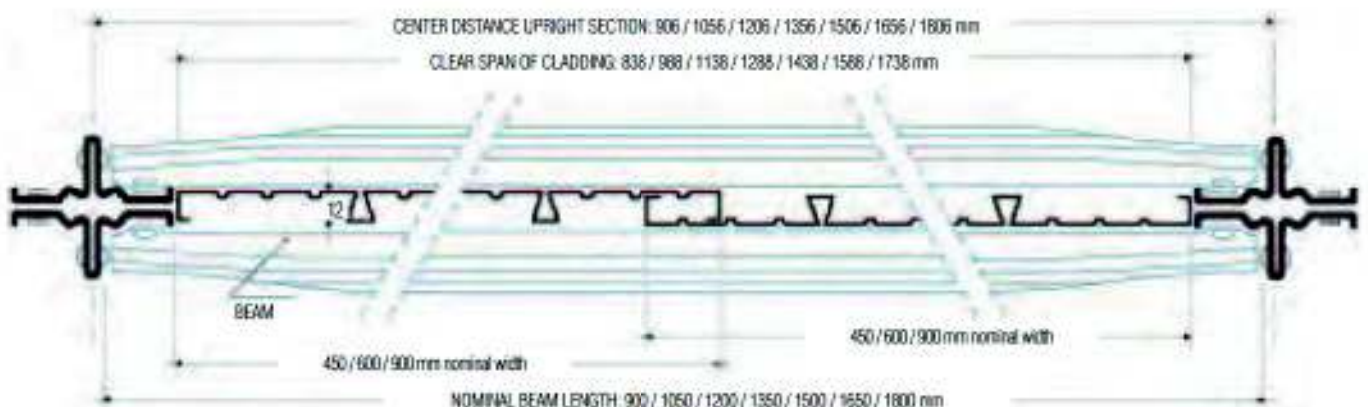

SUPER 3 Two-tier-structures with suspended walkways

(max. load bearing capacity = 300 daN/m²)

Two tier structures, even varied and complex have been designed by METAL-SISTEM combining light weight with high strength in the METALSISTEM tradition, avoiding any type of bolting or welding.

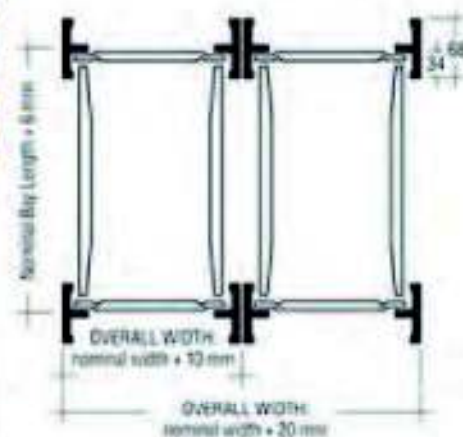

When designing two tier structures, consider the dimensions and details of the sketch shown above. Always refer and adhere to the calculation and safety code summarized on pages 4 and 5.

Max. shelf bay length: 1500 mm
Max. width of walkway: 1200 mm

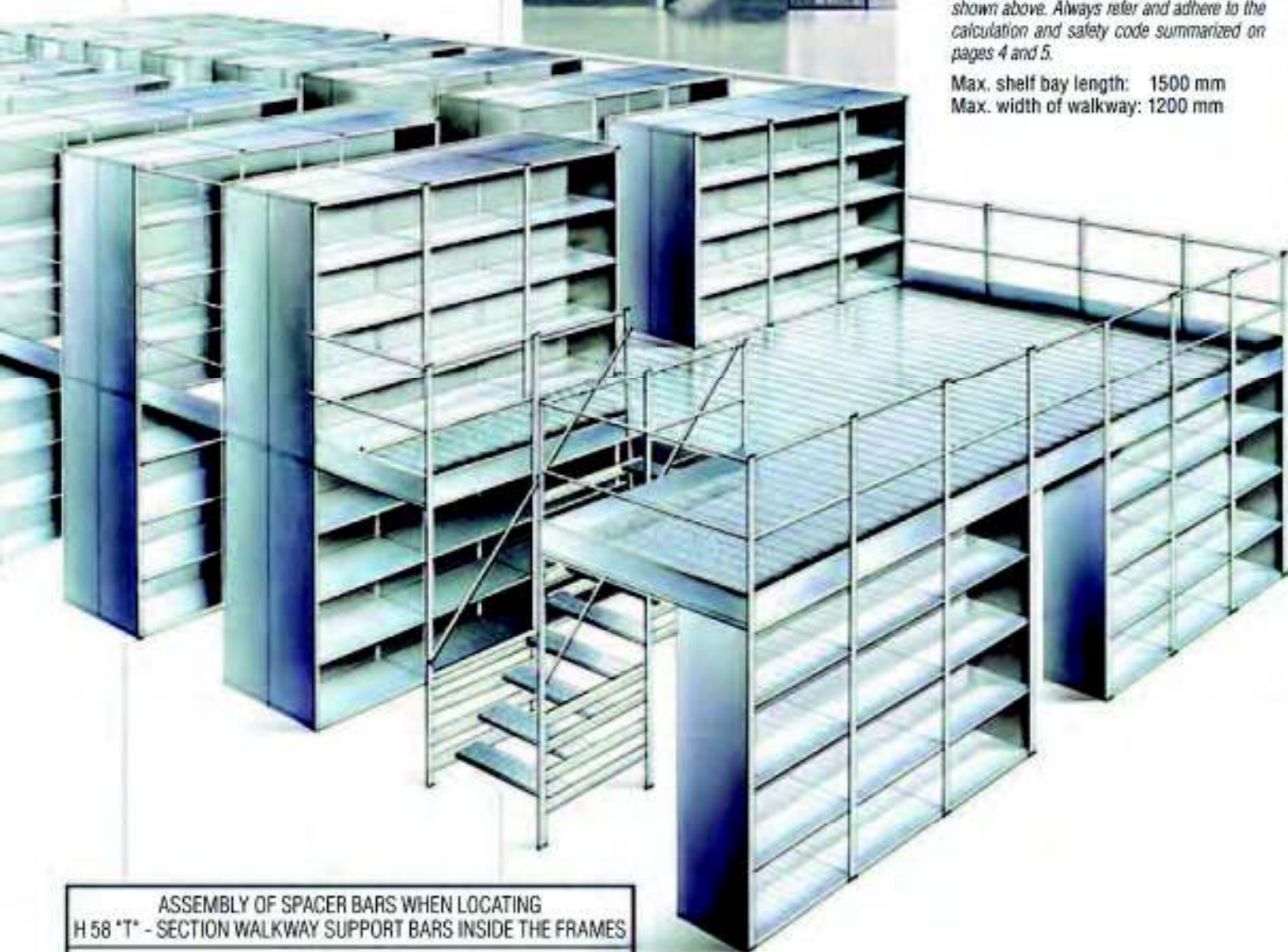

ASSEMBLY OF SPACER BARS WHEN LOCATING H 58 "T" - SECTION WALKWAY SUPPORT BARS INSIDE THE FRAMES

L 900 : NO SPACER BAR

L 1200 : ONE SPACER BAR AT THE CENTRE

L 1500 : ONE SPACER BAR AT THE CENTRE

NOTE:

- The spacer bars connecting the "T"-walkway support bars must be ordered in a special length (30 mm narrower than those used to assemble the standard frame).
- When building staircases, customers should fit one spacer bar under each stair tread.

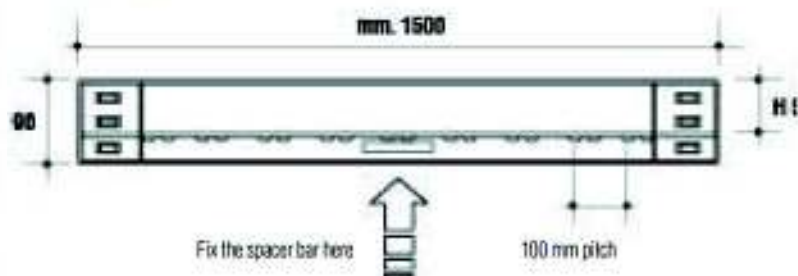

Steel planks

These can be supplied with three different surfaces: ribbed, open and smooth, together with compensation panels and fastening components. The steel planks are inserted into the "T"-section supports by levering between the panel and the support (Ref. 32). There are two types of steel planks: one for walk-through bays and one for walkways. When ordering, always refer to the length of the respective spacer bar used for building the walkway or the frames (see page 48).

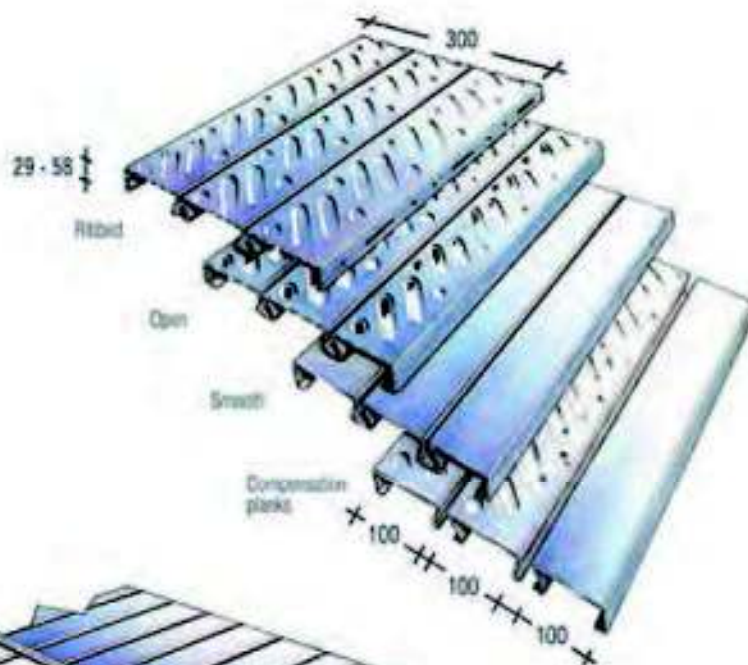

"T"-Section Support Bracket - at 90°

"T"-Section support bars can be located at 90° by assembling one half of a wall fastening bracket (art. n° 65022.95 - Ref. 34) and one half of a "T"-section support bracket (art. n° 67022.95 - Ref. 33).

Wall fastening brackets are also available, similar to the above, providing a method to fix the frames to a wall for stability (Ref. 34).

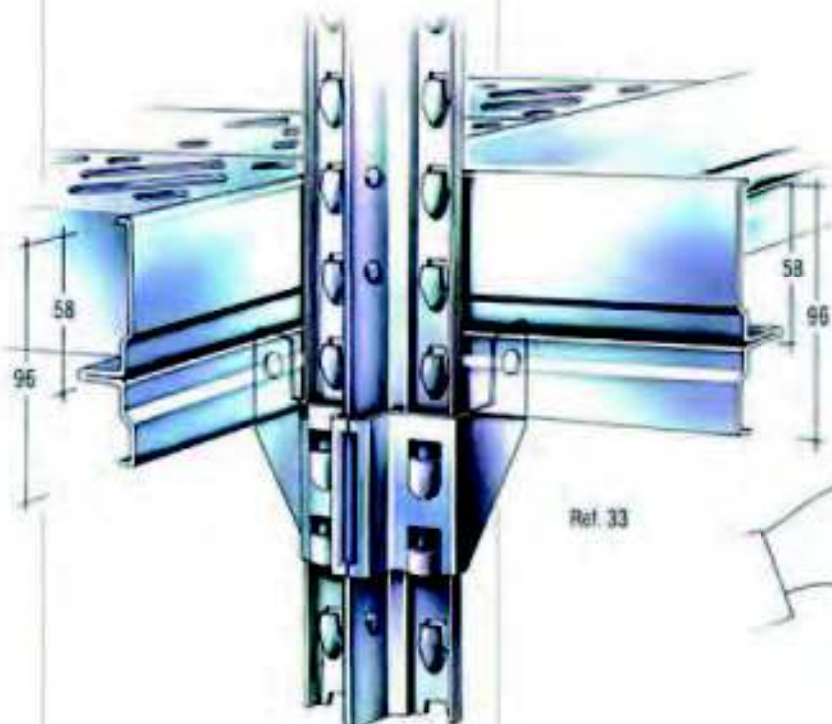
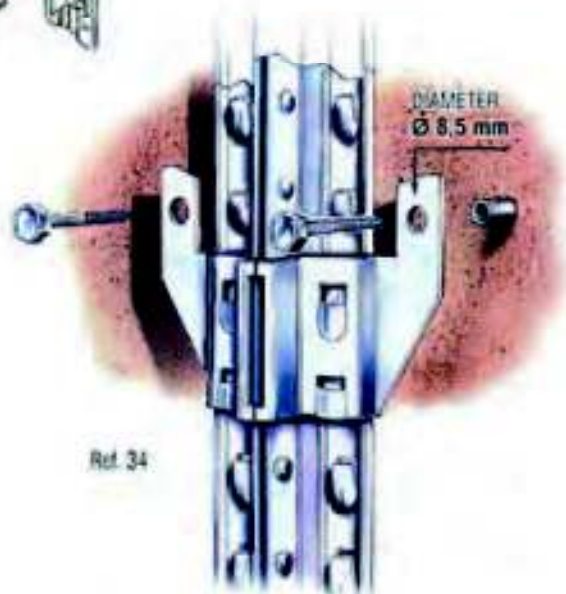

Assembly Instructions SUPER-3 Two tier structures

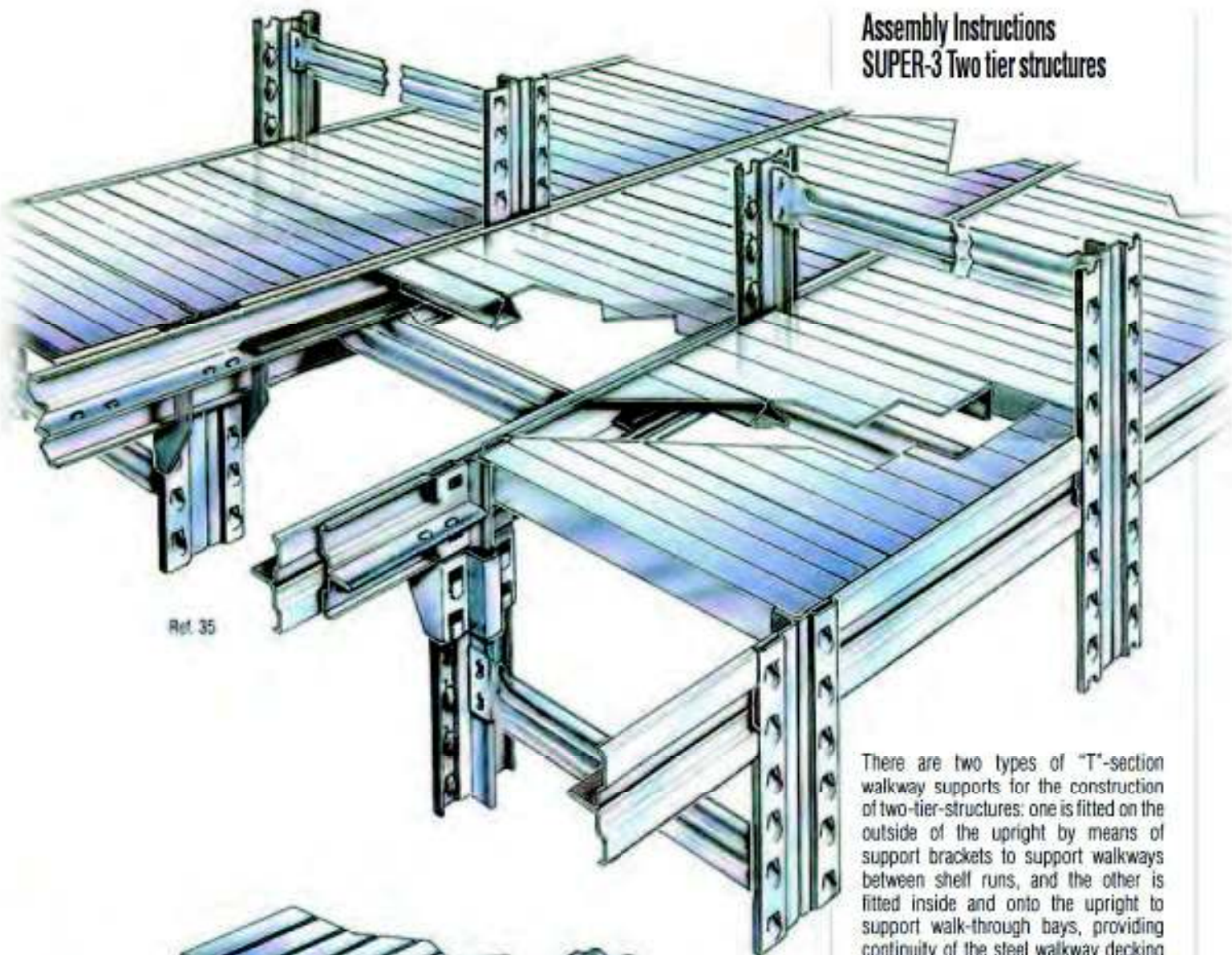

There are two types of "T"-section walkway supports for the construction of two-tier-structures: one is fitted on the outside of the upright by means of support brackets to support walkways between shelf runs, and the other is fitted inside and onto the upright to support walk-through bays, providing continuity of the steel walkway decking (Ref. 38)

The ribs on the "T"-section walkway support beams H58 allow these beams to be connected between them by means of spacer bars being 10 mm narrower than those used to assemble the respective frame (Ref. 35). To reduce noise, a PVC strip is fitted between the steel planks and the "T"-section support bars (Ref. 37). To achieve a correct assembly of the "T"-section support beams within walkways (art. n° 67015.95) these spacer bars must be located under the walkway support beams, at centre distances of 800 mm approximately (Ref. 35/36).

In order to avoid sharp edges, the "T"-section supports should be assembled with an overhang of about 2 cm and finished off with plastic top caps (Ref. 42).

For fixing back-to-back frames together use the two-tier support bracket, bending the tongues behind the second upright, as shown on Ref. 37.

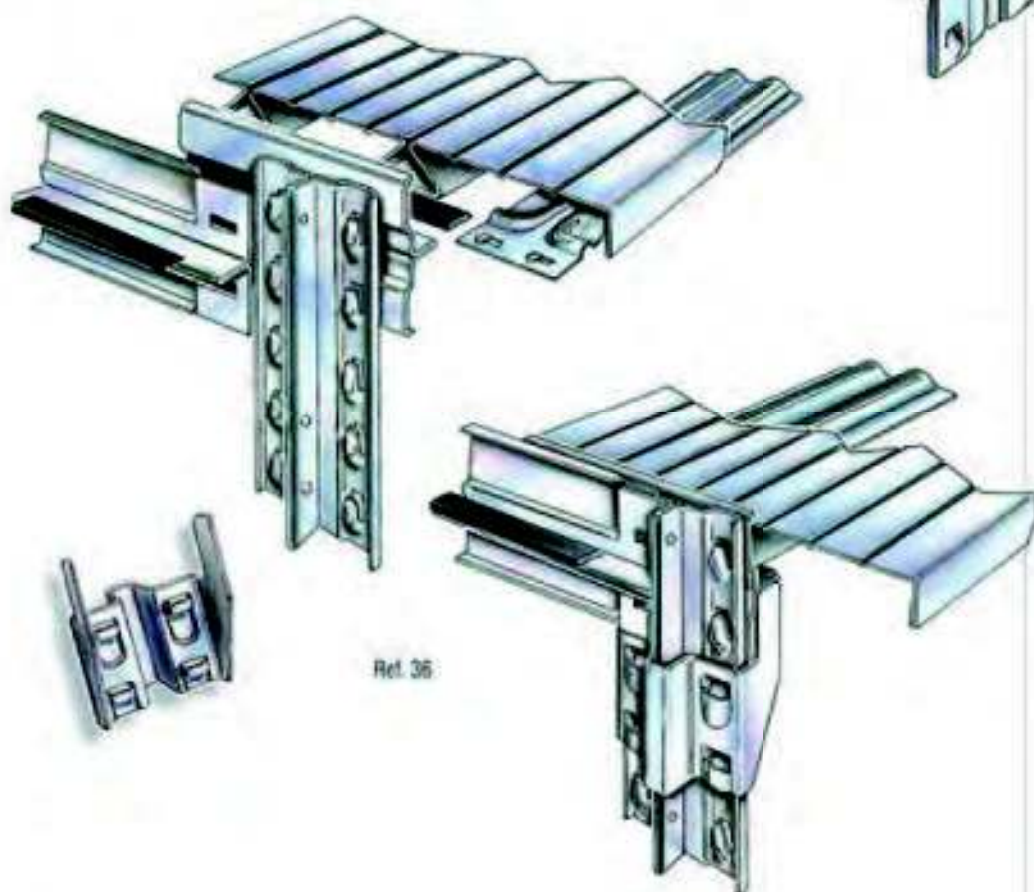

When designing two-tier structures, remember that the overall width of every frame and every walkway will be about 10 mm more than the length of the spacer bar used. Also, when calculating the total length of runs, allow for approximately 6 mm of "creep" per bay (see page 26).

When using any other type of flooring, it is important to note that the floor panel itself will be 4 mm narrower than the spacer bars used to assemble the walkways and respectively 12 mm narrower than the spacer bars used to assemble walk-through-bays.

In all cases, only SUPER 3 components should be used when designing two-tier structures.

See more



on the web

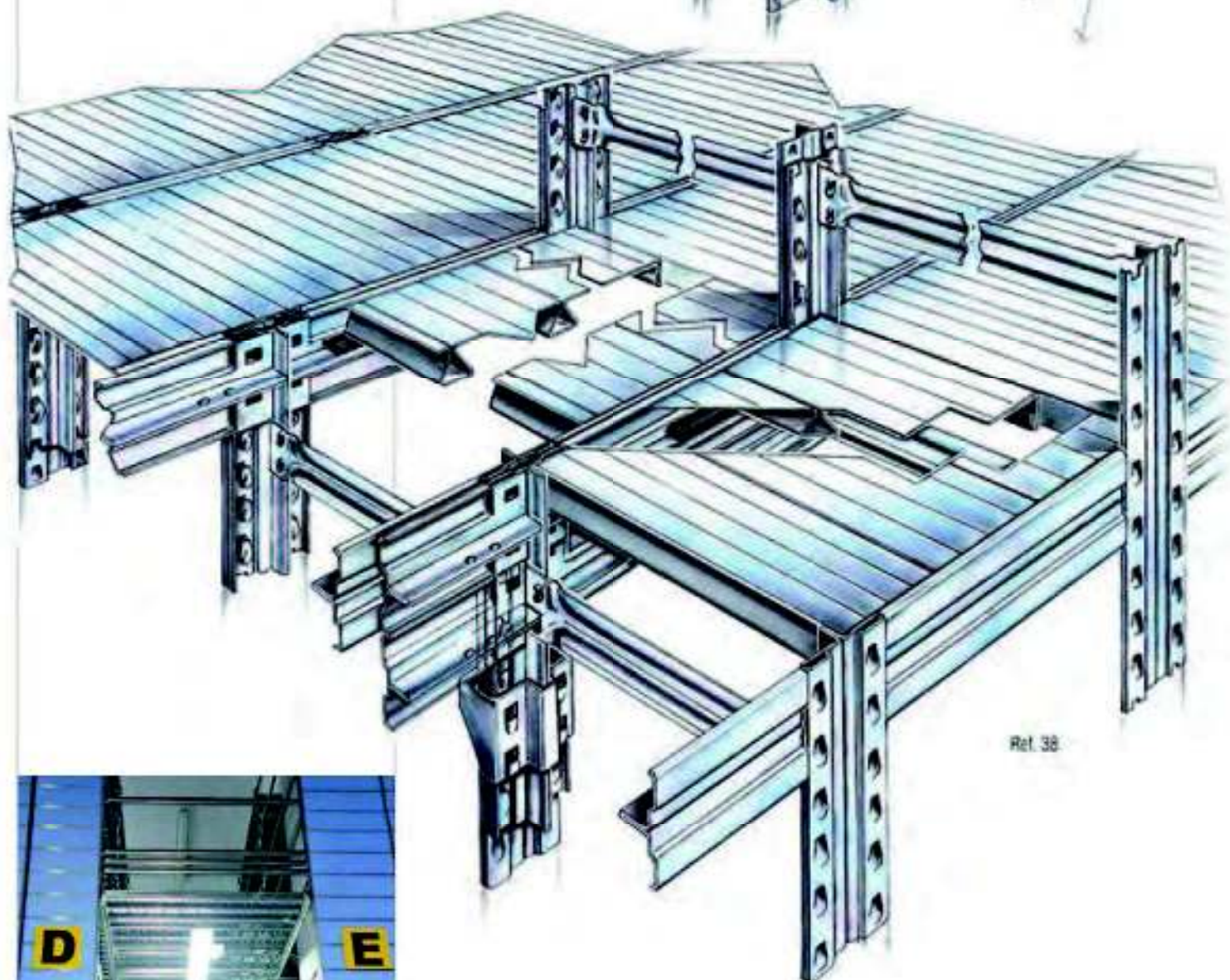
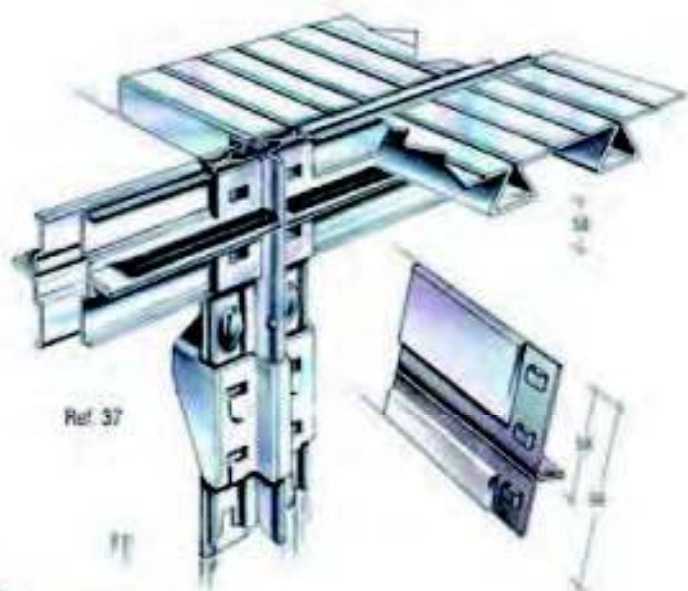

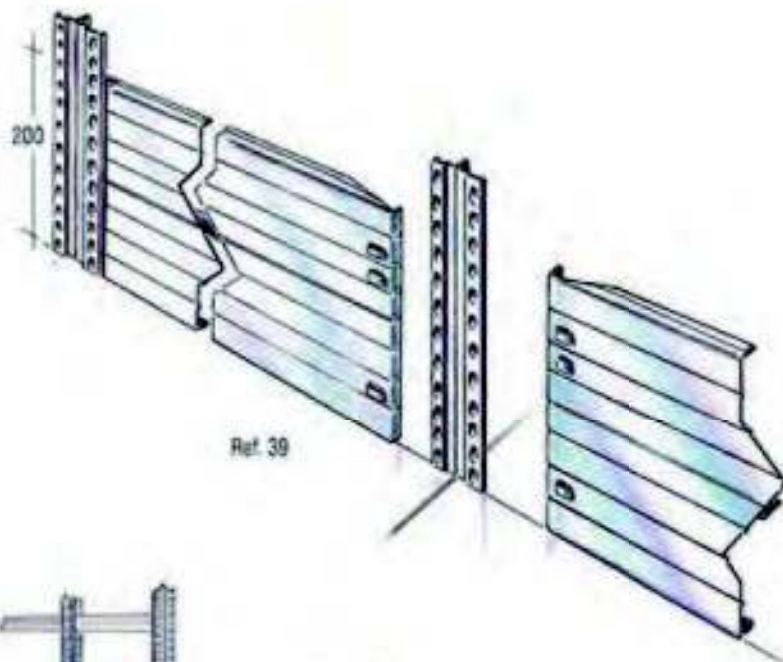

Ref. 39

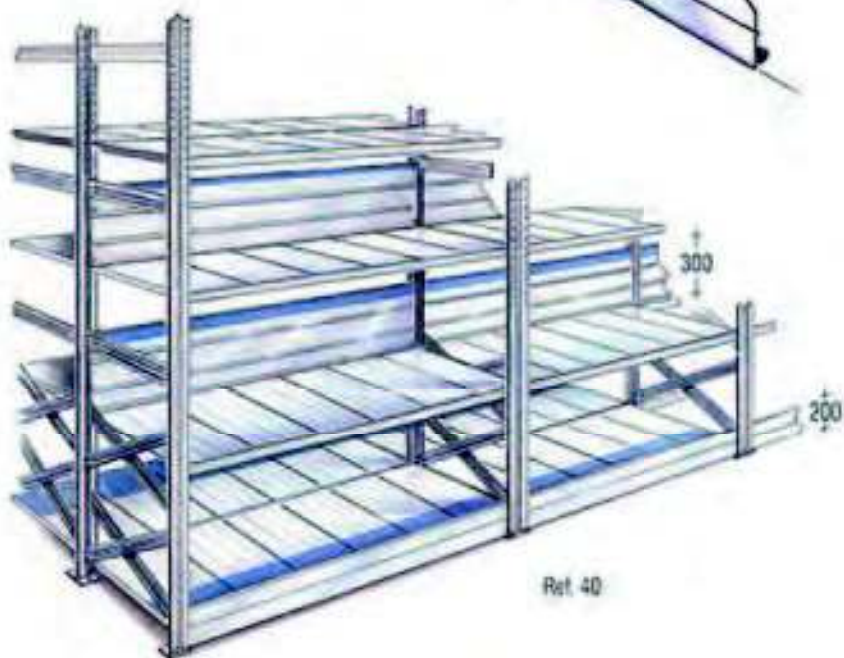

Ref. 40

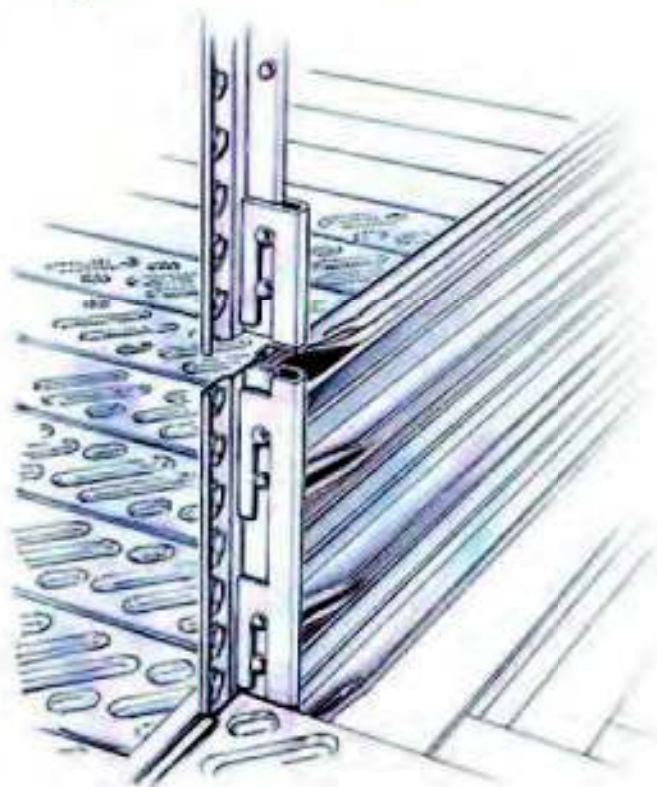

Ref. 50

Kickboards

Three different types of kickboards are available: for use in the direction of the beams, at the end of a run within uprights, or for walkway ends.

Kickboards are made from two oval shaped tubes (the same items used to build the handrails) fixed to the uprights and finished off with a metal sheet element located onto the oval shaped tubes by self tapping screws. For correct ordering of these items and dimensions, please see instructions on page 48 of this brochure.

The use of beam retaining clips is mandatory.



In the direction of the beams, shelf boards are available in two different heights, 200 or 300 mm (art. n° 64016.95 - 64040.95).

These items have flanged ends with slots to be located onto the uprights (Ref. 39).

Upright reinforcement

Uprights that are used as newel posts for handrail should always be fitted with the reinforcing brackets shown (Ref. 50).



Staircase handrails

The handrail tube is a square profile in \varnothing 32x32 mm section, available in both stainless steel and zinc coated version. The fastening of the handrail onto the uprights is made by nylon components and brackets, as shown in the picture below (Ref. 45).

The necessary components have been included into a macro code, for easy ordering. Please refer to page 50 of this brochure.



Hand rails

Hand rails and knee rails are made from oval shaped beams (Ref. 49). For correct ordering of these items, please see instructions on page 48 of this brochure.

The use of beam retaining clips and upright tops caps is mandatory.

Handrails on two-tier structures may also be built with "U"-Section profiles assembled in conjunction with special PVC supports (Ref. 47-48).

These supports can also be used to finish off the handrails at their ends.



Ref. 44

inclination 42°

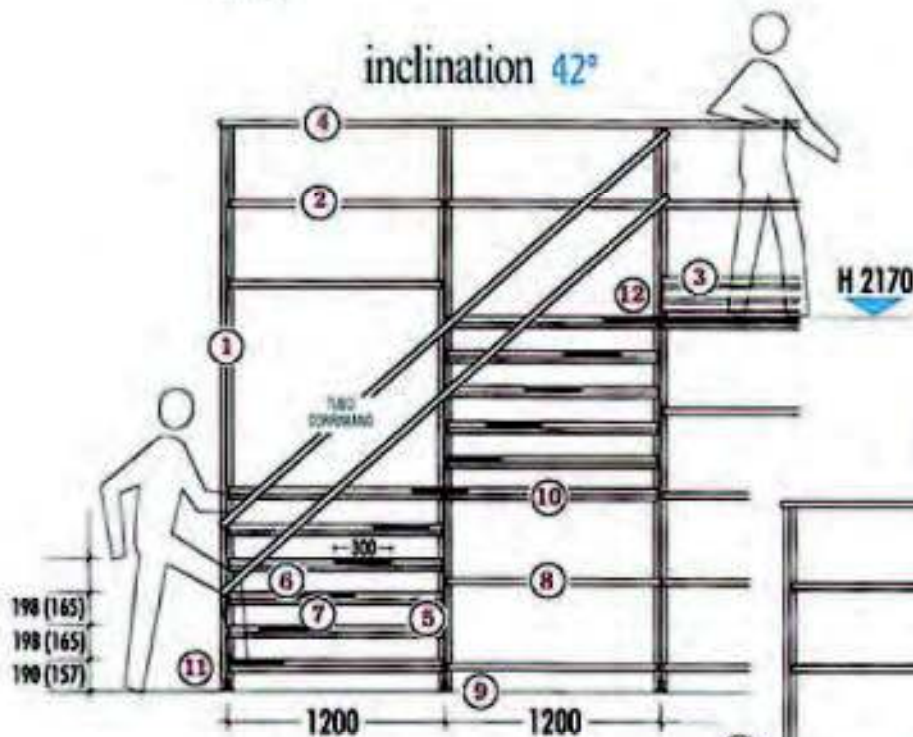

inclination 38°

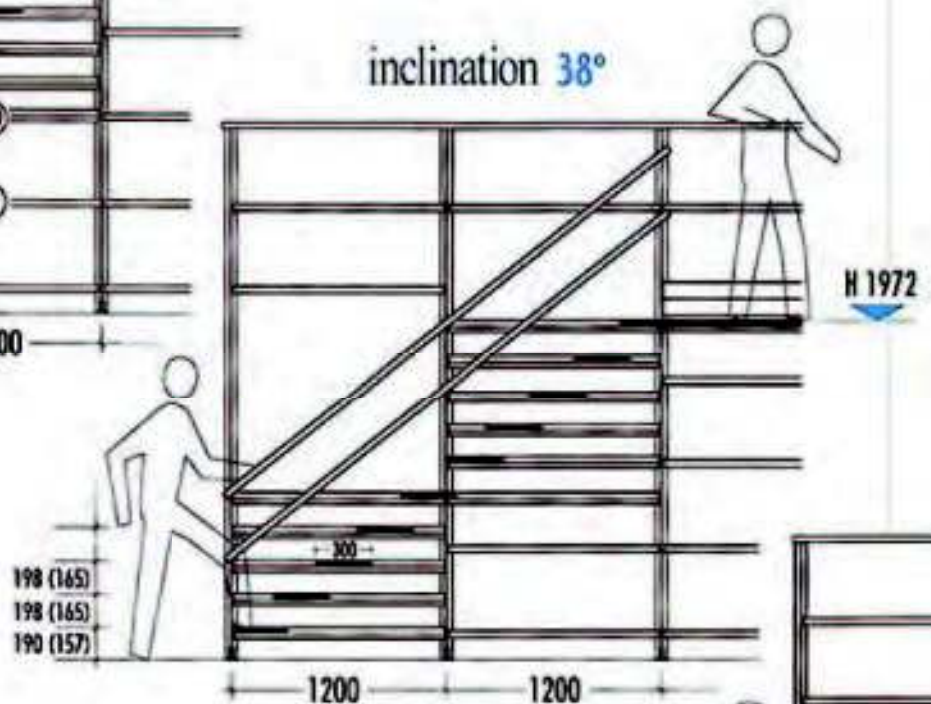

1		REINFORCED UPRIGHT	7		STAR TREAD ANTI-SLIP STEEL PLANK H58 - 15/10
2		TUBULAR BEAM	8		BEAM NUT
3		SHelf BOARD	9		HEAVY DUTY STEEL BASE PLATE
4		U-SECTION HANDRAIL	10		T-SECTION WALKWAY SUPPORT BAR
5		BRACKET CLIP	11		LOCKING FRAME SPACER BAR
6		SPACER BAR TO BE LOCATED UNDER EACH STAR TREAD	12		REINFORCING BRACKET FOR UPRIGHTS

STAIRCASES

Staircases can be built using standard components and integrated into SUPER-3 two-tier structures. The stair treads are fixed with four clamps/screws each (art. n° 69829.95/00056.20). Under each stair tread, one spacer bar has to be assembled into the "T"-section support bar H58, to improve overall stability of the construction.

Staircases have to be adequately reinforced. It is mandatory to use reinforced uprights (art. n° 99230.95: SUPER-3 upright section with welded

"U"-Section profile on its front face) on either side of the staircase, i.e. on all those uprights that are not connected by frame bracing elements. When ordering, customers have to indicate the height of the reinforcement profile (see page 50).

It is recommended to continue with the regular frame bracing pattern within these frames, as soon as possible.

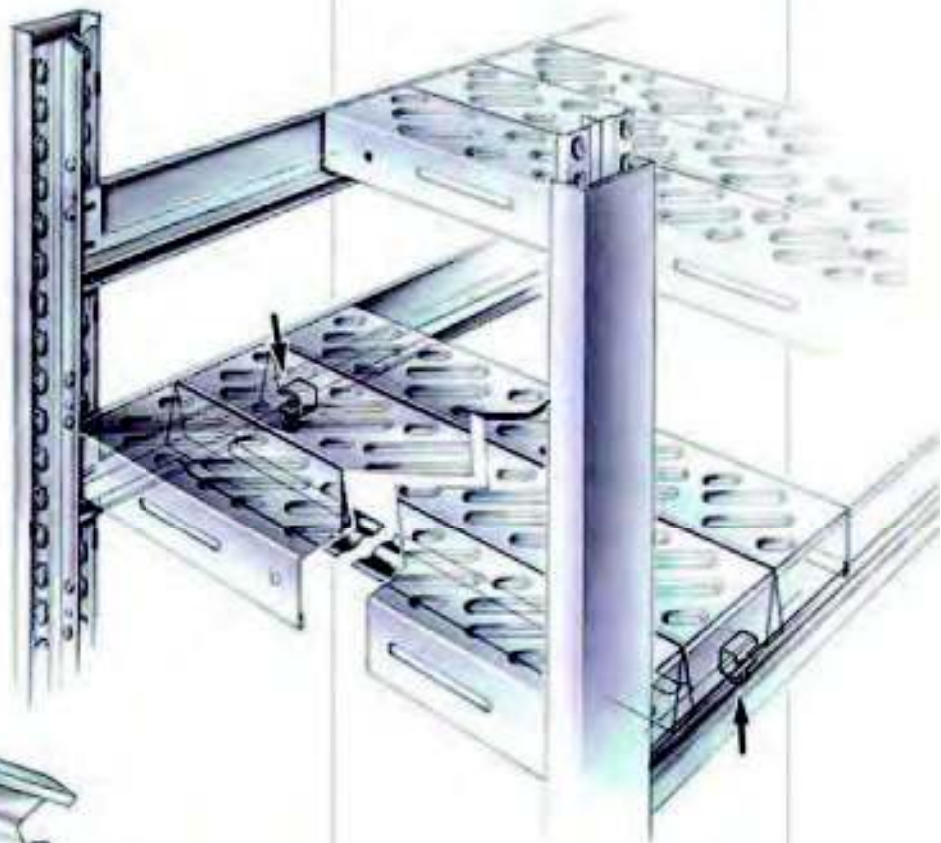
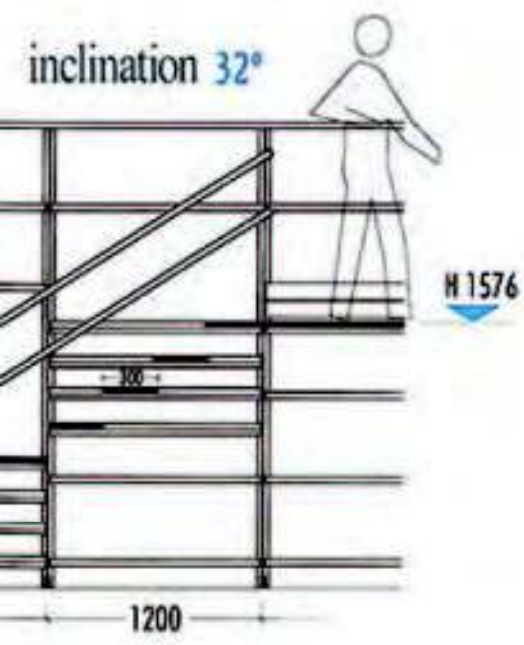



SUPER 1-2-3 shelving system integrated with EUROSCACCO shelf panels

The SUPER 1-2-3 shelving series can be integrated with EUROSCACCO shelf panels. This combination provides specific advantages for shopfitting applications, such as an enhanced choice among various display solutions.

EUROSCACCO shelf panels can be equipped and customised with a huge array of accessory items, such as wire dividers and front risers. This system is available for frames of the SUPER-1 series with a maximum height of 2500 mm.

EUROSCACCO shelves are available in smooth and perforated version, in 1000-1250-1333 mm length, to suit frame depths ranging from 300 to 700 mm, providing a load bearing capacity of 70 daN per shelf, for uniformly distributed loads. SUPER 1 frames, when integrated with EUROSCACCO shelf panels, require vertical bracing - please refer to page 39.

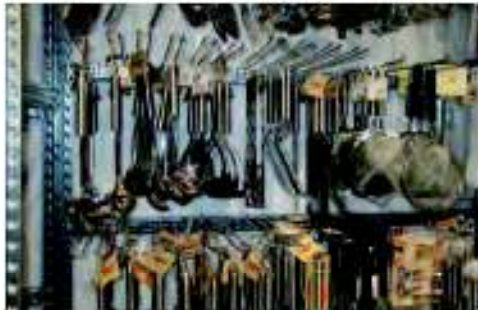

Shopfitting accessories

A wide range of hooks, wire rods, and bars with pegs are available for supply.

These items fit onto the oval beams in 10/10 and 16/10 mm gauge (art. n° 36051.95-36810.95 - see pages 38 and 48 of this brochure).



Trendy Shopfitting and Display Solutions

Achieved with the modular SUPER 1-2-3 shelving series. See pictures at left.



Sliding Doors

Sliding Doors are ideal for areas with limited corridor width and can be used to create closed spaces or cupboards. Sliding doors are supplied preassembled and are available in the standard METALSISTEM colour range. A lock is supplied as a standard accessory with every door. Sliding doors are available for 900-1200-1500 mm bay lengths, in two different heights: 2000 and 2500 mm.

The sliding rails are made to match the height of the shelving beams on top and at the bottom of the shelving bay. In case of MOBIBASIC mobile shelving installations, the rails are fixed directly to the MOBIBASIC chassis and to the shelving beam on top of the bay, to ensure a dust proof connection. For more information and ordering, please refer to page 42.



Mobile Shelving

Thanks to its attractive high-tech design, SUPER 1-2-3 is also a highly suitable and cost effective system to achieve mobile shelving applications. For the design and ordering of mobile shelving installations, please refer to the MOBIBASIC Technical Manual <Doc: MT16>.



Modular Steel Cabinets

Made from our shelving series and clad with EUROSCACCO steel panels, these cabinets are equipped with lockable sliding doors and are highly performing in terms of load bearing capacity. Available in zinc coated or powder coated version (Ref. 62). The standard configuration has been conceived with four modular, adjustable steel shelves made from SUPER-1-beams and H-12-shelf panels; other configurations can be easily achieved thanks to the modular design. Customers may use shelving components from their stock to build the framework and just order the cladding set to build the cabinet. Compared to similar products available on the market, METALSISTEM steel cabinets distinguish themselves by higher load capacities, utmost cost efficiency and solidity. Available as well in a width of 1500 mm: a feature that is not common for this product category. For ordering, see page 42.



Mobile Ladders

Mobile ladders are available in 2000-2500-3000 mm height (in 5-7-9-step version) and can be supplied with guide rail and curves to adapt them to any environment (Ref. 56). For ordering please refer to page 47.



See more



on the web

Steel planking

"T"-sections can be used as support beams for the steel planking (Ref. 55). Floors of any dimension can be built in conjunction with "H" joints and "U" section channels.

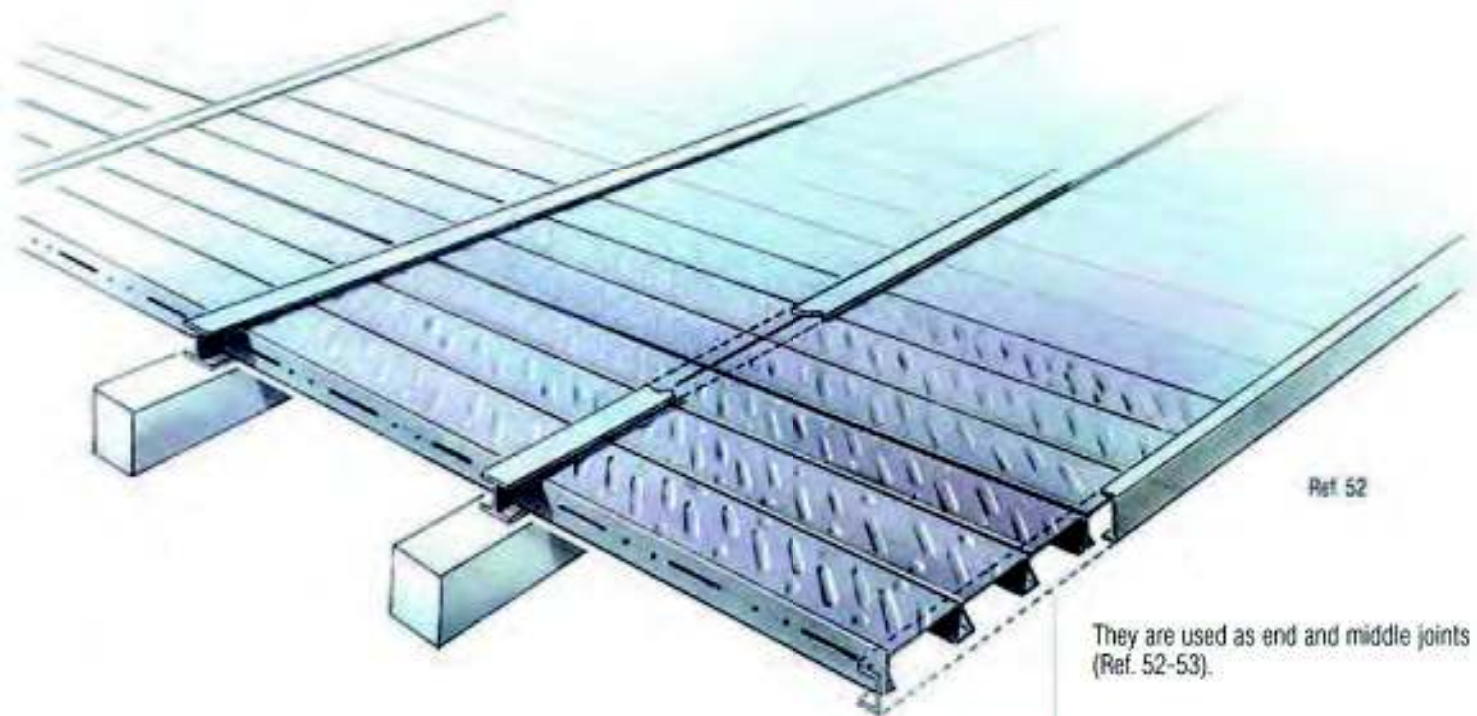

They are used as end and middle joints (Ref. 52-53).

The 70 mm-section walkway beam (art. 99253B.B1) provides an alternative solution to the use of the "T"-section support bars. It enables the steel planks to be laid in length direction along the walkways (Ref. 57).

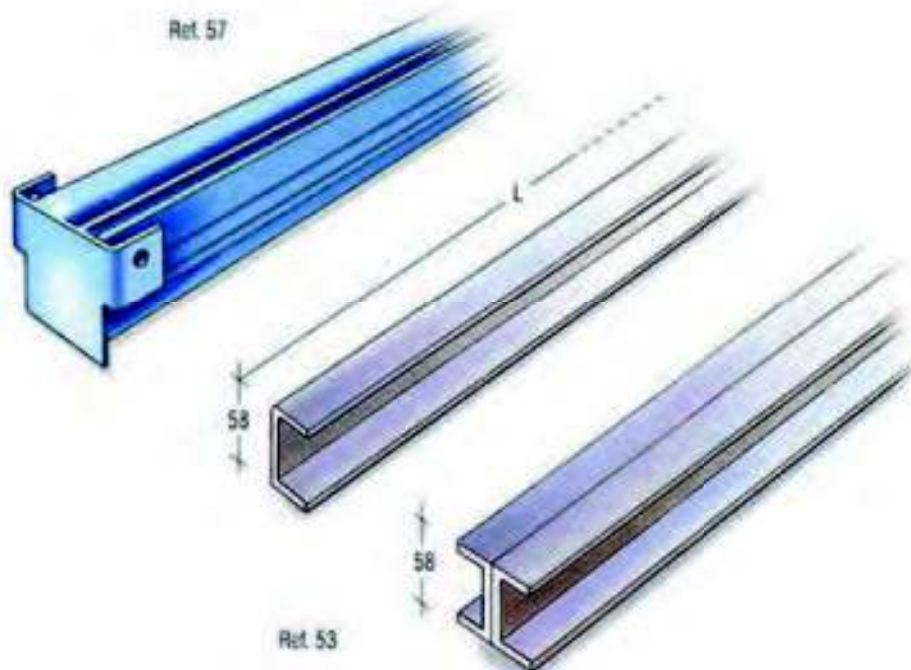

The "T"-section supports are fitted back-to-back. One is fitted on the outside of the upright by means of support brackets, and the other is fitted inside and onto the upright.

The steel planks are laid over the top and are fixed down by means of the special clamp (Ref. 54).

When joining the planks in a transverse direction the 6x20 mm bolt should be used in the appropriate holes.



Ref. 54



Ref. 55